

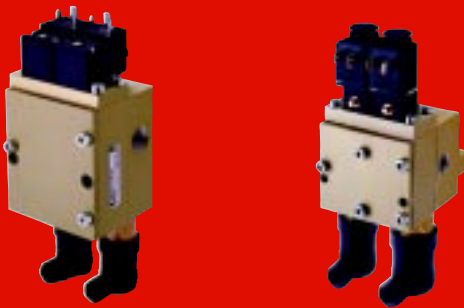

BULLETIN 380B

SERPAR[®] CROSSFLOW PRESS CONTROL DOUBLE VALVES

**Introducing New
Size 1 & 2
SERPAR[®] Crossflow
Double Valves**



• Manufacturers of Premium Pneumatic Controls since 1921 •

ROSS ASIA

ROSS CONTROLS

ROSS EUROPA

ROSS UK

Why Use A Double Valve?

A double valve is designed to promote safety in the operation of many pneumatically controlled machines, and satisfy regulatory requirements for valves used on mechanical power presses employing pneumatically controlled clutch and brake mechanisms.

A ROSS double valve has two valve elements independently controlled by two solenoid pilot valves. The two valve elements share common inlet, outlet, and exhaust ports. When the pilot valves are simultaneously energized, the two main elements are operated simultaneously so that during normal operation the valve functions like a three-way valve with a single element.

If one of the valve elements does not open or close in sync with the other, the valve is designed to keep the pressure on the outlet port at less than two percent of the

inlet pressure. This is an inherent safety characteristic of ROSS' double valve design. Valve element redundancy provides a safety factor as the likelihood of both valve elements malfunctioning on the same cycle is considered extremely remote.

IMPORTANT NOTE: *A mechanical power press or other hazardous machines using a pneumatically-controlled clutch and brake mechanism should use a double valve with a self-contained monitoring device and/or external monitoring system which inhibits further operation of the valve and machine in the event of a failure within the valve. Of course, a double valve is just one of the components in a press control system, and all other elements of the system should be planned with safety as a primary consideration.*

SERPAR® Crossflow Double Valves

The design of the SERPAR® Crossflow double valve is distinguished by crossflow passages and spool valving on the main valve stems. This arrangement provides the valve's unique flow characteristics.

VALVE SIZES: ROSS double valves are now available in six sizes, providing a full range of sizes to meet your needs. For convenience, valves are designated by the nominal sizes 1, 2, 4, 8, 12, and 30. These sizes approximate an average of the flow coefficients (C_v) of the various flow paths through the valve. Further information about C_v ratings is given on page 18.

MONITORS: Self-contained monitors, designed to inhibit valve operation in case of a fault within the valve, are built

into the valve assemblies of sizes 4, 8, 12, and 30 valves. There are three types of ROSS monitors available: pneumatic (L-G), electro-pneumatic (E-P), and electronic (D-S).

PRESSURE SWITCHES: Size 1 and 2 valves are available with pressure switches for incorporation into press control systems with external monitors. Customers may design their own external monitoring system to work in conjunction with these valves. This option puts complete control in the hands of the customer and lets *their* external monitoring system make all shut-down/lock-out decisions.

VALVE ELEMENT CONSTRUCTION: The dual valve elements are of lightweight construction. Their low inertia allows them to respond quickly to actuating and deactuating forces. Impact loads are also kept small to help assure long valve life. Each valve element is guided at the top by the piston and at the bottom by the stainless steel stem, and there is no sliding bearing surface between.

The Leader in Double Valve Design

ROSS has long been in the forefront of double valve research and development. For over 45, years ROSS has been responding to the needs of press manufacturers by developing and supplying double valves of different types. Internal flow patterns have included series flow, parallel flow, and combined series flow.

Monitoring devices have also been offered in a variety of designs to satisfy differing requirements. The manifestation of all this experience is seen in the present line of SERPAR® Crossflow double valves described in this brochure.

Selecting the double valve best suited to each application requires considerable technical knowledge. If you need information or application assistance, please consult ROSS (see back cover).

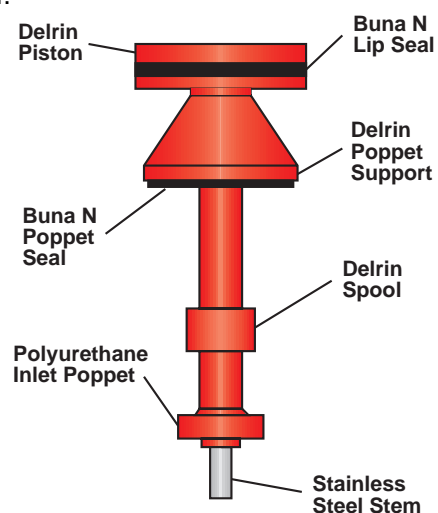

Overview of SERPAR® Crossflow Function

AIR FLOW PATHS: Parallel flow paths develop equal forces on the valve elements in both the actuated and deactuated modes. This enables both valve elements to respond equally to pilot pressures and promotes synchronous movement of the valve elements. The air flow paths for the valves in different operating modes are shown below.

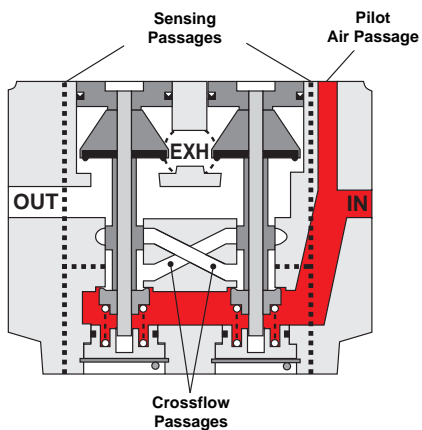

VALVE ELEMENTS DEACTUATED: With both inlet poppets closed, inlet air pressure holds each poppet firmly against its seat. Exhaust poppets are open to an oversized exhaust port, and sensing pressure signals are zero. Sensing passages (shown as dashed lines) transmit pressure signals upward or downward depending on the location of the monitoring device being used.

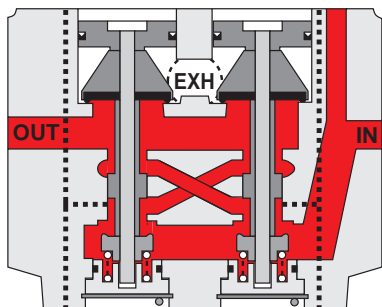

VALVE ELEMENTS ACTUATED: With the valve elements in the actuated position, inlet air is free to flow past the two inlet poppets and through the two crossflow passages to the outlet port. The exhaust poppets close off the exhaust port, and sensing pressure signals become equal to inlet pressure.

When the valve is returned to the deactuated position (see figure at top of this page), the design of the spool elements (on the valve stem) allows any pressure remaining in the sensing or crossflow passages to be exhausted through the open exhaust port.

CONTENTS

	Page
General Information	2-3
Operation of Monitors and Pressure Switches	4-7
Valves with L-G (Pneumatic) Monitor	
Size 4	8-9
Sizes 8, 12, 30	10-11
Valves with E-P (Electro-pneumatic) Monitor (Sizes 8, 12, 30	12-13
Valves with D-S (Electronic) Monitor	
Sizes 8, 12, 30	14-15
Valves with & without Pressure Switches (Non-Monitored), Sizes 1 & 2	16-17
Valve Response Times	18
C _v Ratings	18
Cautions & Warranty	19

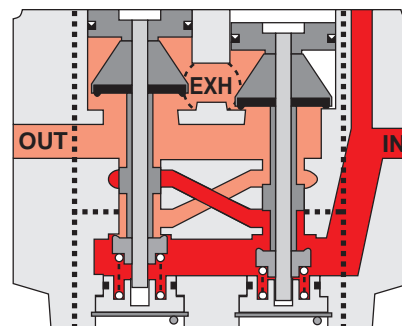

DETECTING A MALFUNCTION: A malfunction in the system or in the valve itself could cause one valve element to be open and the other closed. In this event inlet air from the open inlet poppet is substantially blocked from the outlet port by the spool on the closed valve element. The large size of the open exhaust passage serves to keep the pressure at the outlet port below two percent of the inlet pressure.

The sensing pressure signal from the open valve element is equal to inlet pressure, while the sensing signal from the closed valve element is very small. The internal or external monitor senses the difference between these two pressures and uses this information to shut down the valve and inhibit further valve action. After the cause of the malfunction has been corrected and the electrical signal has been removed from the pilot solenoid, the monitor can be reset and normal operation can be resumed.

SERPAR® Crossflow Double Valves with L-G Monitor

Specifications on pages 8-11.

CONDITIONS AT START

Inlet 1 is closed to outlet 2 by both valve elements A and B. Outlet 2 is open to exhaust 3. Pilot air is ported from inlet 1 and through the center section of spool S to the normally closed pilots Pa and Pb. Monitoring pressure signals at both ends of spool S are exhausted.

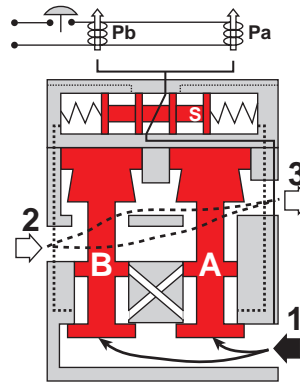

NORMAL OPERATION

Simultaneously energizing both solenoids actuates both pilots and causes valve elements A and B to shift. Inlet 1 is then connected to outlet 2 via crossflow passages C and D. Exhaust 3 is closed. Monitoring pressure signals go to each end of spool S and become equal to inlet pressure.

COMPLETION OF NORMAL CYCLE.

Simultaneously deenergizing both solenoids returns the valve to the "Conditions at Start" described above.

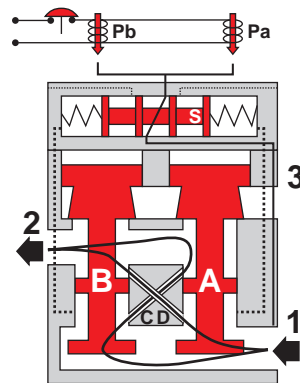

DETECTING A MALFUNCTION

A malfunction in the system or the valve itself could cause one valve element to be open and the other closed. Air then flows past the inlet poppet on valve element A, into crossflow passage D, but is substantially blocked by the spool portion of element B. The large size of the open exhaust passage past element B keeps the pressure at the outlet port below two percent of inlet pressure. Full monitoring air pressure from side A goes to the right end of spool S, and a reduced pressure goes to the left end. This pressure imbalance causes the spool to shift to the left. This shuts off and exhausts pilot air to both solenoid pilots, and allows valve element A to return to the closed position.

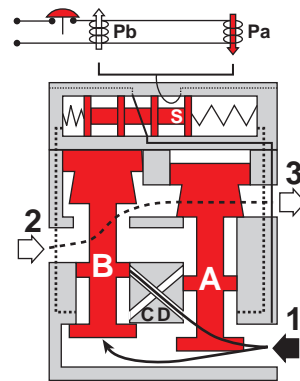

L-G MONITOR LOCKED OUT

When the L-G spool shifts it is held by a lockout pin (not shown). Pilot air is then exhausted to atmosphere via port YB, and pilot supply air is diverted to atmosphere via port YA. The lockout mechanism must be reset before the valve can return to normal operation. *During and following reset, the pilot solenoids must be kept deenergized to prevent inadvertent and possibly dangerous cycling of the press.* The reset function is either manual or remote-pneumatic depending on valve model.

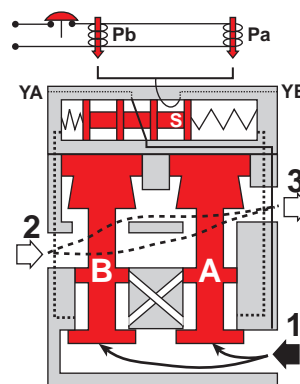

SERPAR® Crossflow Double Valves with E-P Monitor

Specifications on pages 12-13.

CONDITIONS AT START

Inlet 1 is closed to outlet 2 by both valve elements A and B. Outlet 2 is open to exhaust 3. Contacts of switch SW are closed. Monitoring pressure signals at both ends of spool S are exhausted.

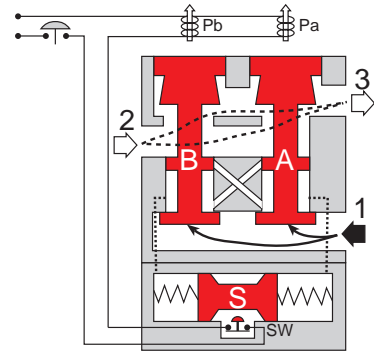

NORMAL OPERATION

Simultaneously energizing both solenoids actuates both pilots and causes valve elements A and B to shift. Inlet 1 is then connected to outlet 2 via crossflow passages C and D. Exhaust 3 is closed. Monitoring pressure signals go to each end of spool S, and become equal to inlet pressure.

COMPLETION OF NORMAL CYCLE.

Simultaneously deenergizing both solenoids returns the valve to the "Conditions at Start" described above.

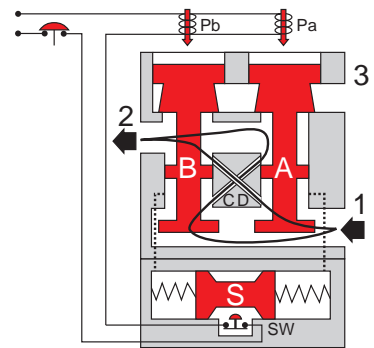

DETECTING A MALFUNCTION

A malfunction in the system or the valve itself could cause one valve element to be open and the other closed. Air then flows past the inlet poppet on valve element A, into crossflow passage D, but is substantially blocked by the spool portion of element B. The large size of the open exhaust passage past element B keeps the pressure at the outlet port below two percent of inlet pressure. Full monitoring air pressure from side A goes to the right end of spool S, and a reduced pressure goes to the left end. This pressure imbalance causes the spool to shift to the left. This trips switch SW, breaks the electrical circuit to the pilot solenoids, and allows valve element A to return to the closed position.

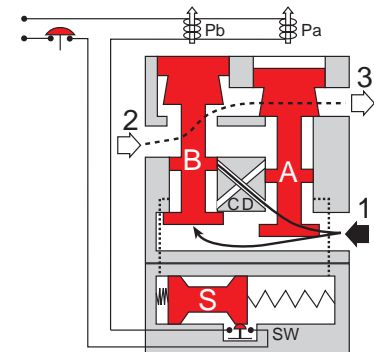

E-P MONITOR LOCKED OUT

With both valve elements closed, monitoring air pressure is exhausted from both ends of spool S so that it returns to its normal position. The electrical circuit to the pilot solenoids remains broken by switch SW. To restore the electrical circuit and return the valve to normal operation, the reset solenoid (not shown) must be briefly energized to reset switch SW. *During and following reset, the pilot solenoids must be kept deenergized to prevent inadvertent and possibly dangerous cycling of the press.* Prolonged energizing of the reset solenoid can cause burnout and nullify the reset function.

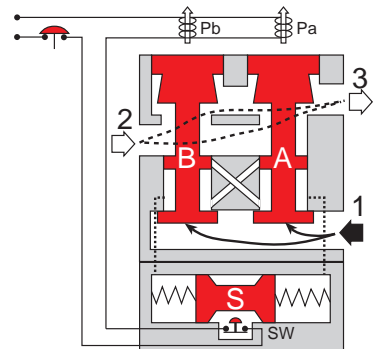

SERPAR® Crossflow Double Valves with D-S Monitor

Specifications on pages 14-15.

CONDITIONS AT START

Inlet 1 is closed to outlet 2 by both valve elements A and B. Outlet 2 is open to exhaust 3. Contacts of switch SW are closed. Monitoring pressure signals at both ends of spool S are exhausted.

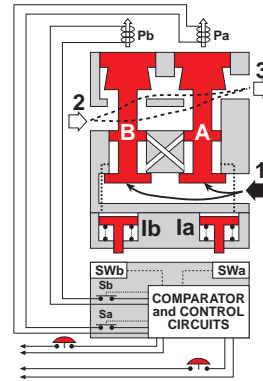

NORMAL OPERATION

Simultaneously energizing both solenoids actuates both pilots and causes valve elements A and B to shift. Inlet 1 is then connected to outlet 2 via crossflow passages C and D. Exhaust 3 is closed. Monitoring pressure signals go to pressure indicators Ia and Ib, causing the indicator pins to be extended and to actuate proximity switches SWa and SWb. In normal operation, each pair of solenoids, valve elements, indicators, and proximity switches, responds in unison so that the comparator circuits “read” the operation as normal.

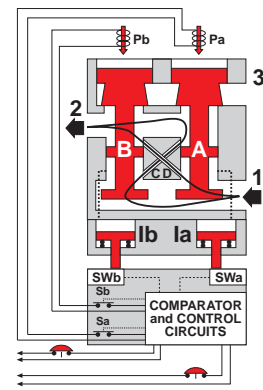

COMPLETION OF NORMAL CYCLE.

Simultaneously deenergizing both solenoids returns the valve to the “Conditions at Start” described above.

DETECTING A MALFUNCTION

A malfunction in the system or the valve itself could cause one valve element to be open and the other closed. Air then flows past the inlet poppet on valve element A, into crossflow passage D, but is substantially blocked by the spool portion of element B. The large size of the open exhaust passage past element B keeps the pressure at the outlet port below two percent of inlet pressure. Full monitoring air pressure from side A goes to pressure indicator Ia so that its pin is extended and actuates proximity switch SWa. When the time interval between the signal to a solenoid and the signal from its corresponding proximity switch exceeds approximately 175 milliseconds, the D-S monitor breaks contacts Sa and Sb as soon as solenoid power is removed. This allows valve element A to return to the closed position.

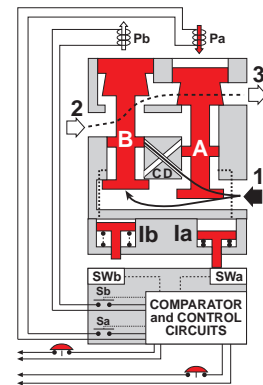

D-S MONITOR LOCKED OUT

With the valve locked out by contacts Sa and Sb, solenoids Pa and Pb cannot be energized. The monitor must be reset before another valve cycle can begin. Reset can be achieved by a separately connected ancillary switch, but not if the pilot solenoids are energized. *The monitor can be reset by removing and reapplying power to the monitor even when the pilot solenoids are energized. For this reason, it is necessary to have the pilot solenoids deenergized during and following reset to prevent inadvertent and possibly dangerous cycling of the press.*

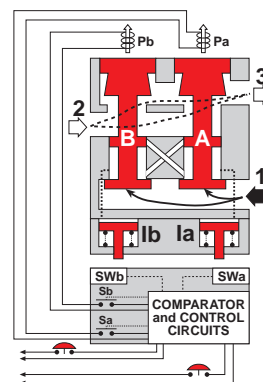

SERPAR® Crossflow Double Valves with Pressure Switches*

Specifications on pages 16-17.

CONDITIONS AT START

Inlet 1 is closed to outlet 2 by both valve elements A and B. Outlet 2 is open to exhaust 3. Pressure signals at both switches SWA and SWB are exhausted. Contacts 1 and 2 of switches SWA and SWB are connected.

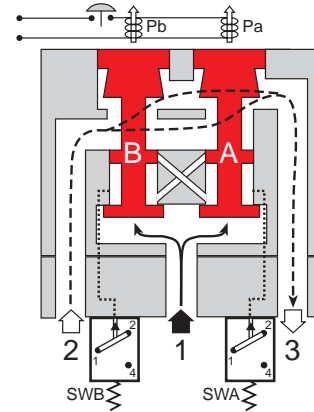

NORMAL OPERATION

Simultaneously energizing both solenoids actuates both pilots and causes valve elements A and B to shift. Inlet 1 is then connected to outlet 2 via crossflow passages C and D. Exhaust 3 is closed. Sensing pressure signals go to each pressure switch and become equal to inlet pressure. Both switches trip and now contacts 1 and 4 of switches SWA and SWB are connected instead of contacts 1 and 2.

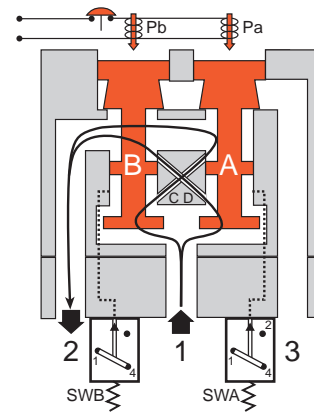

COMPLETION OF NORMAL CYCLE.

Simultaneously de-energizing both solenoids returns the valve and switches to the "Conditions at Start" described above.

DETECTING A MALFUNCTION

A malfunction in the system or the valve itself could cause one valve element to be open and the other closed. Air then flows past the inlet poppet on valve element A, into crossflow passage D, but is substantially blocked by the spool portion of element B. The large size of the open exhaust passage past element B keeps the pressure at the outlet port below 2 % of inlet pressure. Full sensing air pressure from side A goes to switch SWA, and a reduced pressure goes to switch SWB. This full pressure signal causes switch SWA to trip. Switch SWB, with a reduced pressure signal, does not trip. An external monitoring system can detect the malfunction by monitoring the condition of the switches SWA and SWB. The external monitoring system may then react accordingly by shutting down the power to the valve solenoids and any other components deemed necessary to stop the machine. See note below.

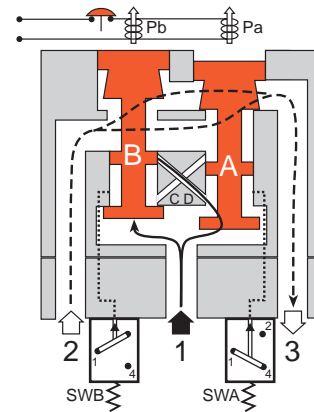

***NOTE:** These models have two pressure switches that sense pressure in the sensing ports resulting from the movement of corresponding valve elements. The pressure switches only indicate if the valve elements do not move in unison. The switches will not lock out the valve without the addition of an external monitoring system and should not be confused with a monitor. If lock-out capability is advisable for your application, be sure to connect the pressure switches to an external monitor. If an internal monitor is preferred, use a model with LG, EP, or DS monitor.

These models are also available with: 1) no pressure switches installed, but with provision for installing pressure switches later, or 2) with no switches installed and no provision for installing them later. The models with no provision for pressure switches are not capable of being monitored and should not be used in applications where lock-out capability is a requirement, i.e. press clutch/brakes.

SWITCH OPERATION: Each pressure switch has four electrical contacts. Contacts 1 and 2 are connected when no air pressure signal is applied to the switch. Contacts 1 and 4 are connected when an air pressure signal is applied to the switch. Contact 3 is for a ground connection. For further information in the use or connection of the pressure switches call your local ROSS distributor or, in the U.S.A., call ROSS Technical Services at 1-888-TEK-ROSS.

SERPAR Crossflow Double Valves with L-G Monitor

Size 4



STANDARD SPECIFICATIONS

Pilot Solenoids: Two, rated for continuous duty.
Standard voltages: 100 – 110 volts 50 Hz; 100 – 120 volts 60 Hz; 24, 110 volts DC. Other voltages available.
Power Consumption: Each solenoid, 30 VA inrush, 16 VA holding on 50 or 60 Hz; 11 watts on DC.
Electrical Connections: Uses cord-grip connectors at solenoids. Order connectors separately.
Ambient Temperature: 4 to 50°C (40 to 120°F).
Media Temperature: 4 to 80°C (40 to 175°F).
Flow Media: Filtered air.
Pressure Range: 2 to 7 bar (30 to 100 psig).
Reset Pressure: Remote pneumatic reset models require a pressure of at least 2 bar (30 psig). Manual reset models use internal valve pressure.
Inlet Port: Models are available with the inlet port on either the right or the left side of the valve body. NPT threads. For other threads, see page 18.

IMPORTANT NOTE: Please read carefully and thoroughly all of the CAUTIONS on page 19.

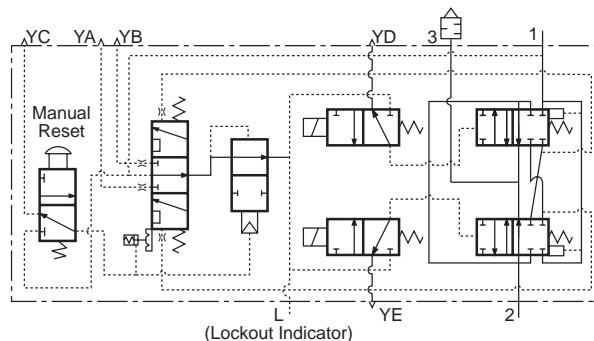

VALVE OPERATION

Both solenoids must be energized simultaneously to shift the valve; maintained signal required to keep valve shifted.
WARNING: If monitor must be reset, electrical signals to both solenoids must be removed to prevent the machine controlled by the valve from immediately recycling and producing a potentially hazardous condition.

OPTIONS

Valve Without Piping Flanges: See below.
Valve Without Silencer: Exhaust port has threaded flange only. Consult ROSS.

Valve Response Time (msec) = M + F • V
 Average time required to fill volume V (cubic inches) to 90 percent of supply pressure or to exhaust it to 10 percent of supply pressure. M and F values are shown in chart below. See *Valve Response Time* on page 18. C_v ratings also on page 18.

VALVE MODEL NUMBERS and MODEL SPECIFIC INFORMATION

Port Size	Monitor Reset	Model Numbers		Avg. Response Constants			Weight lbs (kg)
		Right Inlet	Left Inlet	M	F		
					1 to 2	2 to 3	
3/8	Manual Remote	3573D3191 3573D3192	3573D3195 3573D3196	15	0.70	0.40	8.1 (3.7)
1/2	Manual Remote	3573D4211 3573D4212	3573D4215 3573D4216	15	0.65	0.35	
3/4	Manual Remote	3573D5211 3573D5212	3573D5215 3573D5216	15	0.65	0.35	
VALVE MODELS WITHOUT PIPING FLANGES (For replacement purposes)							
All	Manual Remote	3573D4241 3573D4242	3573D4245 3573D4246	See corresponding size above.			7.5 (3.4)



ELECTRICAL CONNECTORS

Electrical connectors are required to connect the valve solenoids to the drop cords supplying electrical power. Each connector can be positioned so that the cord exits upward or to the side. Cords of 6-mm to 10-mm diameter can be

used. Connectors with a light in a translucent housing are also available to serve as indicator lights. Order connectors by the part numbers given in the chart below.

WIRED CONNECTORS have a 2-meter (6-1/2 ft.) cord with three 18-gauge conductors. Cord exits upward, and is available in either 6-mm or 10-mm diameter.

CONNECTORS for THREADED CONDUIT accept 1/2-inch electrical conduit fittings.

Part Numbers of Electrical Connectors		
Connector Type	Without Light	With Light*
For use with dropcord (Cord not included)	937K87	936K87
Wired with 6-mm cord	721K77	720K77
Wired with 10-mm cord	371K77	383K77
For use with threaded conduit	723K77	724K77

* Specify solenoid voltage.

RESET VALVES for L-G MONITOR

On valve models with manual reset a button on the side of the monitor is pushed to perform the reset function. Models for remote reset, however, require a small reset valve and the installation of a 1/8 line from the reset valve to the reset port on the monitor. ROSS offers 3/2 normally closed valves with either manual or electric control that are suitable for this purpose. The following valves (illustrated on page 11) are suggested:

Model Numbers of Reset Valves

Description	Valve Model Numbers
Pushbutton: Green	1223A1005
Red	1223A1006
Direct Solenoid Control for line mounting	1613B1020
Direct Solenoid Control for base mounting	W1413A1409 (Base: 516B91)

PIPING FLANGE KITS

Each kit includes two threaded flanges and the required seals and mounting bolts. Available in three NPT sizes. Order by the following kit numbers:

Pipe Size	Kit Number
3/8.....	658K77
1/2.....	659K77
3/4.....	660K77

DIMENSIONS inches (mm)

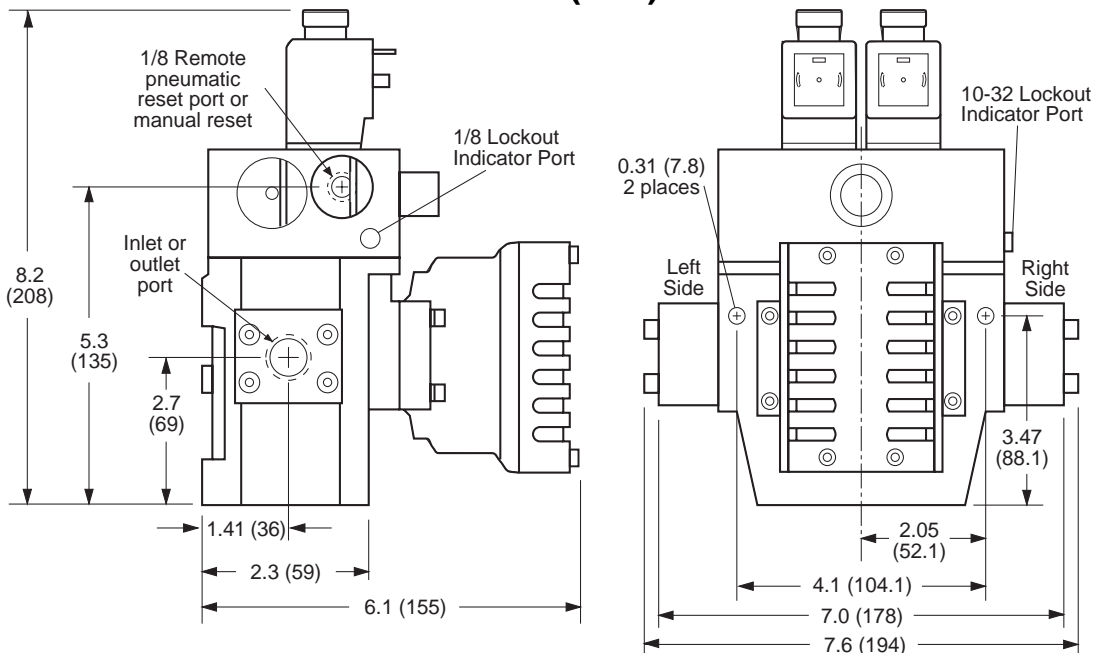

SERPAR Crossflow Double Valves with L-G Monitor

Sizes 8, 12, 30

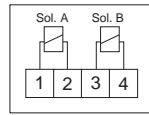

Wiring Diagram

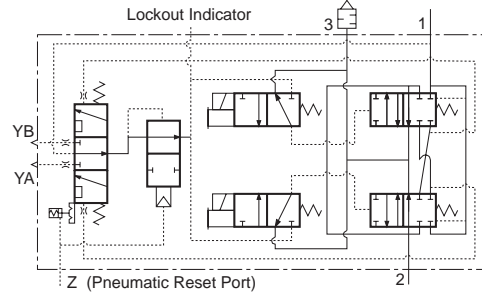

VALVE OPERATION

Both solenoids must be energized simultaneously to shift the valve with a maintained signal required to keep valve shifted. **WARNING: If monitor must be reset, electrical signals to both solenoids must be removed to prevent the machine controlled by the valve from immediately recycling and producing a potentially hazardous condition.**

OPTIONS

Valve Without Piping Flanges: See below.

Valve Without Silencer: Exhaust port has threaded flange only. Consult ROSS.

STANDARD SPECIFICATIONS

- Pilot Solenoids:** Two, rated for continuous duty.
- Standard voltages:** 100 – 110 volts 50 Hz; 100 – 120 volts 60 Hz; 24, 110 volts DC. Other voltages available.
- Power Consumption:** Each solenoid, 87 VA inrush, 30 VA holding on 50 or 60 Hz; 14 watts on DC.
- Electrical Connections:** Terminal strip.
- Ambient Temperature:** 4 to 50°C (40 to 120°F).
- Media Temperature:** 4 to 80°C (40 to 175°F).
- Flow Media:** Filtered air.
- Pressure Range:** 2 to 8.5 bar (30 to 125 psig).
- Reset Pressure:** 4 bar (60 psig) minimum.
- Inlet Port:** NPT threads. For other threads, see page 18.

IMPORTANT NOTE: Please read carefully and thoroughly all of the CAUTIONS on page 19.

Valve Response Time (msec) = M + F • V
Average time required to fill volume V (cubic inches) to 90 percent of supply pressure or to exhaust it to 10 percent of supply pressure. M and F values are shown in chart below. See *Valve Response Time* on page 18. C_v ratings also on page 18.

VALVE MODEL NUMBERS and MODEL SPECIFIC INFORMATION

Nominal Size	Port Size	Model Numbers		Avg. Response Constants			Weight lbs (kg)
		With Overrides	Without Overrides	M	F		
					1 to 2	2 to 3	
8	1/2	3573A4142	3573A4162	15	0.70	0.30	15.0 (6.8)
	3/4	3573A5142	3573A5162		0.65	0.23	
	1	3573A6152	3573A6172		0.65	0.23	
12	3/4	3573A5152	3573A5172	20	0.33	0.21	19.0 (8.6)
	1	3573A6162	3573A6182		0.28	0.21	
	1-1/4	3573A7162	3573A7182		0.28	0.21	
30	1-1/4	3573A7152	3573A7172	25	0.19	0.07	37.5 (17.0)
	1-1/2	3573A8162	3573A8182		0.18	0.07	
VALVE MODELS WITHOUT PIPING FLANGES (For replacement purposes)							
8	ALL	3573A4202	3573A4222	See corresponding size above.			13.8 (6.3)
12	ALL	3573A5202	3573A5222				17.5 (8.0)
30	ALL	3573A7202	3573A7222				36.0 (16.4)

RESET VALVES for L-G MONITOR

On valve models with manual reset, a button on the side of the monitor is pushed to perform the reset function. Models for remote reset, however, require a small reset valve and the installation of a 1/8 line from the reset valve to the reset port on the monitor. ROSS offers 3/2 normally closed valves with either manual or electric control that are suitable for this purpose. The valves, pictured at right, are suggested.



Pushbutton Models
Green button: 1223A1005
Red button: 1223A1006

PIPING FLANGE KITS

Each kit includes two threaded (NPT) flanges and the required seals and mounting bolts. Order by the following kit numbers:

Nominal Size	Port Size	Kit Number
8	1/2	661K77
	3/4	662K77
	1	663K77
12	3/4	664K77
	1	665K77
	1-1/4	666K77
30	1-1/4	667K77
	1-1/2	668K77

Direct Solenoid Model for Line Mounting
1613B1020



Direct Solenoid Model for Base Mounting
Valve: W1413A1409
Sub-Base: 516B91

DIMENSIONS inches (mm)

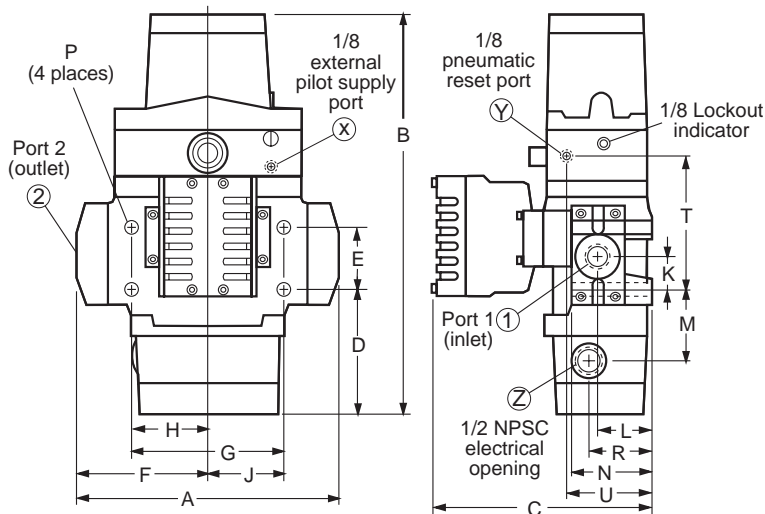

NOTE: For external pilot models consult ROSS.

① ②	1/2, 3/4, 1	3/4, 1, 1-1/4	1-1/4, 1-1/2
(X)	1/8 external pilot supply port		
(Y)	1/8 pneumatic reset port		
(Z)	1/2 NPSC electrical opening		
A	8.52 (216)	8.96 (228)	12.36 (314)
B	12.3 (312)	13.8 (351)	17.8 (451)
C	7.2 (184)	8.6 (216)	11.1 (282)
D	3.7 (93)	4.0 (102)	4.1 (104)
E	2.10 (53.3)	3.0 (76.2)	5.90 (150)
F	4.26 (108)	4.48 (114)	6.18 (157)
G	5.06 (128)	5.50 (140)	8.56 (217)
H	2.53 (64)	2.75 (70)	4.28 (109)
J	2.47 (63)	2.47 (63)	2.47 (63)
K	1.25 (32)	1.81 (46)	4.52 (115)
L	1.80 (46)	1.69 (43)	2.27 (58)
M	2.03 (52)	2.40 (61)	2.50 (64)
N	2.6 (66)	3.0 (76)	3.7 (93)
P	0.28 (7.1)	0.34 (8.7)	0.53 (13.5)
R	2.09 (53)	2.09 (53)	2.65 (67)
S	3.9 (99)	4.8 (121)	8.9 (227)
T	4.33 (110)	5.22 (133)	9.36 (238)
U	2.45 (62)	2.45 (62)	3.02 (77)
V	2.13 (54)	2.13 (54)	2.13 (54)

SERPAR® Crossflow Double Valves with E-P Monitor

Sizes 8, 12, 30

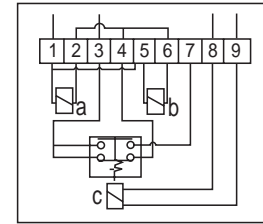
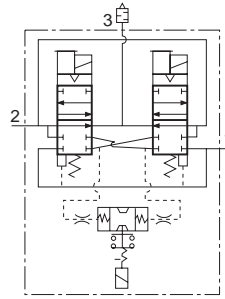

Wiring Diagram

STANDARD SPECIFICATIONS

Pilot Solenoids: Two, rated for continuous duty.
Standard voltages: 100 – 110 volts 50 Hz; 100 – 120 volts 60 Hz; 24, 110 volts DC. Other voltages available.
Power Consumption: Each solenoid, 87 VA inrush, 30 VA holding on 50 or 60 Hz; 14 watts on DC.
Reset Solenoid: Rated for continuous duty. Voltages: 24 – 48 or 100 – 120 volts AC or DC.
Electrical Connections: Terminal strip.
Ambient Temperature: 4 to 50°C (40 to 120°F).
Media Temperature: 4 to 80°C (40 to 175°F).
Flow Media: Filtered air.
Pressure Range: 2 to 8.5 bar (30 to 125 psig).
Ports: NPT threads. For other threads, see page 18.

IMPORTANT NOTE: Please read carefully and thoroughly all of the CAUTIONS on page 19.

VALVE OPERATION

Both solenoids must be energized simultaneously to shift the valve. Signal must be maintained to keep valve shifted. **WARNING: If monitor must be reset, electrical signals to both solenoids must be removed to prevent the machine controlled by the valve from immediately recycling and producing a potentially hazardous condition.** Note: Terminal seven on the terminal strip may be used to indicate lockout condition.

OPTIONS

Valve Without Piping Flanges: See below.
Valve Without Silencer: Exhaust port has threaded flange only. Consult ROSS.

$$\text{Valve Response Time (msec)} = M + F \cdot V$$

Average time required to fill volume V (cubic inches) to 90 percent of supply pressure or to exhaust it to 10 percent of supply pressure. M and F values are shown in chart below. See *Valve Response Time* on page 18. C_v ratings also on page 18.

VALVE MODEL NUMBERS and MODEL SPECIFIC INFORMATION

Nominal Size	Port Size	Model Numbers		Avg. Response Constants			Weight lbs (kg)
		With Overrides	Without Overrides	M	F		
					1 to 2	2 to 3	
8	1/2	3573A4141	3573A4161	15	0.70	0.30	11.5 (5.2)
	3/4	3573A5141	3573A5161		0.65	0.23	
	1	3573A6151	3573A6171		0.65	0.23	
12	3/4	3573A5151	3573A5171	20	0.33	0.21	15.5 (7.0)
	1	3573A6161	3573A6181		0.28	0.21	
	1-1/4	3573A7161	3573A7181		0.28	0.21	
30	1-1/4	3573A7151	3573A7171	25	0.19	0.07	35.0 (16)
	1-1/2	3573A8161	3573A8181		0.18	0.07	
VALVE MODELS WITHOUT PIPING FLANGES							
(For replacement purposes)							
8	ALL	3573A4201	3573A4221	See corresponding size above.			10.3 (4.7)
12	ALL	3573A5201	3573A5221				14.0 (6.4)
30	ALL	3573A7201	3573A7221				33.5 (15.2)

DIMENSIONS inches (mm)

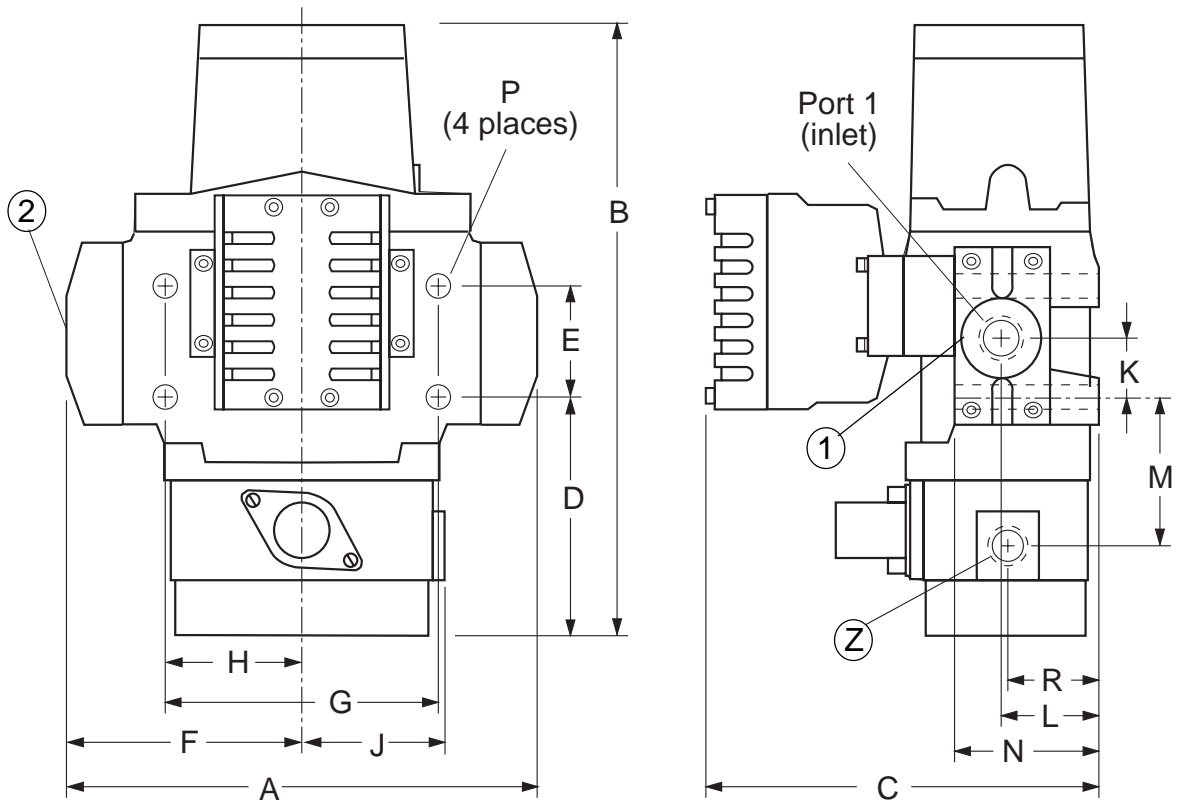

CAUTION ON THE USE OF RESET SOLENOID

The reset solenoid is rated only for intermittent duty. Energizing it continuously will lead to solenoid burnout and nullify the reset function

PIPING FLANGE KITS

Each kit includes two threaded (NPT) flanges and the required seals and mounting bolts. Order by the following kit numbers:

Nominal Size	Port Size	Kit Number
8	1/2	661K77
	3/4	662K77
	1	663K77
12	3/4	664K77
	1	665K77
	1-1/4	666K77
30	1-1/4	667K77
	1-1/2	668K77

DIMENSIONS inches (mm)

① ②	1/2, 3/4, 1	3/4, 1, 1-1/4	1-1/4, 1-1/2
②	1/2 NPSC electrical opening		
A	8.52 (216)	8.96 (228)	12.36 (314)
B	11.44 (288)	12.8 (324)	17.3 (440)
C	7.2 (184)	8.6 (216)	11.1 (282)
D	4.7 (118)	5.0 (127)	5.1 (130)
E	2.10 (53.3)	3.0 (76.2)	5.90 (150)
F	4.26 (108)	4.48 (114)	6.18 (157)
G	5.06 (128)	5.50 (140)	8.56 (217)
H	2.53 (64)	2.75 (70)	4.28 (109)
J	2.63 (67)	2.63 (67)	2.63 (67)
K	1.25 (32)	1.81 (46)	4.52 (115)
L	1.80 (46)	1.69 (43)	2.27 (58)
M	2.44 (62)	2.81 (71)	2.91 (74)
N	2.6 (66)	3.0 (76)	3.7 (93)
P	0.28 (7.1)	0.34 (8.7)	0.53 (13.5)
R	2.70 (43)	1.70 (43)	2.09 (53)

SERPAR® Crossflow Double Valves with D-S Monitor

Sizes 8, 12, 30

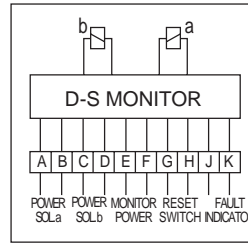
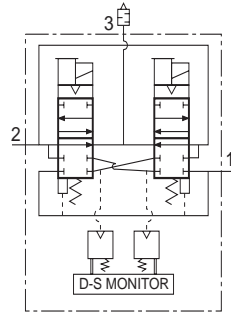

Wiring Diagram

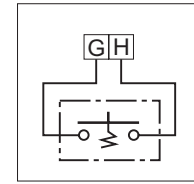

Momentary Reset Switch
with no power applied.
(supplied by customer)

STANDARD SPECIFICATIONS

- Pilot Solenoids:** Two, rated for continuous duty.
- Standard voltages:** 100 – 110 volts 50 Hz; 100 – 120 volts 60 Hz; 24, 110 volts DC. Other voltages available.
- Power Consumption:** Each solenoid, 87 VA inrush, 30 VA holding on 50 or 60 Hz; 14 watts on DC.
- Electrical Connections:** Terminal strip.
- D-S Monitor:** Uses same voltage and frequency as pilot solenoids, but power supply must be independent and continuous.
- Ambient Temperature:** 4 to 50°C (40 to 120°F).
- Media Temperature:** 4 to 80°C (40 to 175°F).
- Flow Media:** Filtered air.
- Pressure Range:** 2 to 8.5 bar (30 to 125 psig).
- Ports:** NPT threads. For other threads, see page 18.

IMPORTANT NOTE: Please read carefully and thoroughly all of the CAUTIONS on page 19.

VALVE OPERATION

Both solenoids must be energized simultaneously to shift the valve with a maintained signal required to keep valve shifted. **WARNING: If monitor must be reset, electrical signals to both solenoids must be removed to prevent the machine controlled by the valve from immediately recycling and producing a potentially hazardous condition.**

OPTIONS

- Valve Without Piping Flanges:** See below.
- Valve Without Silencer:** Exhaust port has threaded flange only. Consult ROSS.

Valve Response Time (msec) = M + F • V
Average time required to fill volume V (cubic inches) to 90 percent of supply pressure or to exhaust it to 10 percent of supply pressure. M and F values are shown in chart below. See *Valve Response Time* on page 18. C_v ratings also on page 18.

VALVE MODEL NUMBERS and MODEL SPECIFIC INFORMATION

Nominal Size	Port Size	Model Numbers		Avg. Response Constants			Weight lbs (kg)
		With Overrides	Without Overrides	M	F		
					1 to 2	2 to 3	
8	1/2	3573B4143	3573B4163	15	0.70	0.30	16.5 (7.5)
	3/4	3573B5143	3573B5163		0.65	0.23	
	1	3573B6153	3573B6173		0.65	0.23	
12	3/4	3573B5153	3573B5173	20	0.33	0.21	20.5 (9.3)
	1	3573B6163	3573B6183		0.28	0.21	
	1-1/4	3573B7163	3573B7183		0.28	0.21	
30	1-1/4	3573B7153	3573B7173	25	0.19	0.07	39.3 (17.8)
	1-1/2	3573B8163	3573B8183		0.18	0.07	
VALVE MODELS WITHOUT PIPING FLANGES (For replacement purposes)							
8	ALL	3573B4203	3573B4223	See corresponding size above			15.3 (6.9)
12	ALL	3573B5203	3573B5223		19.0 (8.6)		
30	ALL	3573B7203	3573B7223		37.8 (17.2)		

DIMENSIONS inches (mm)

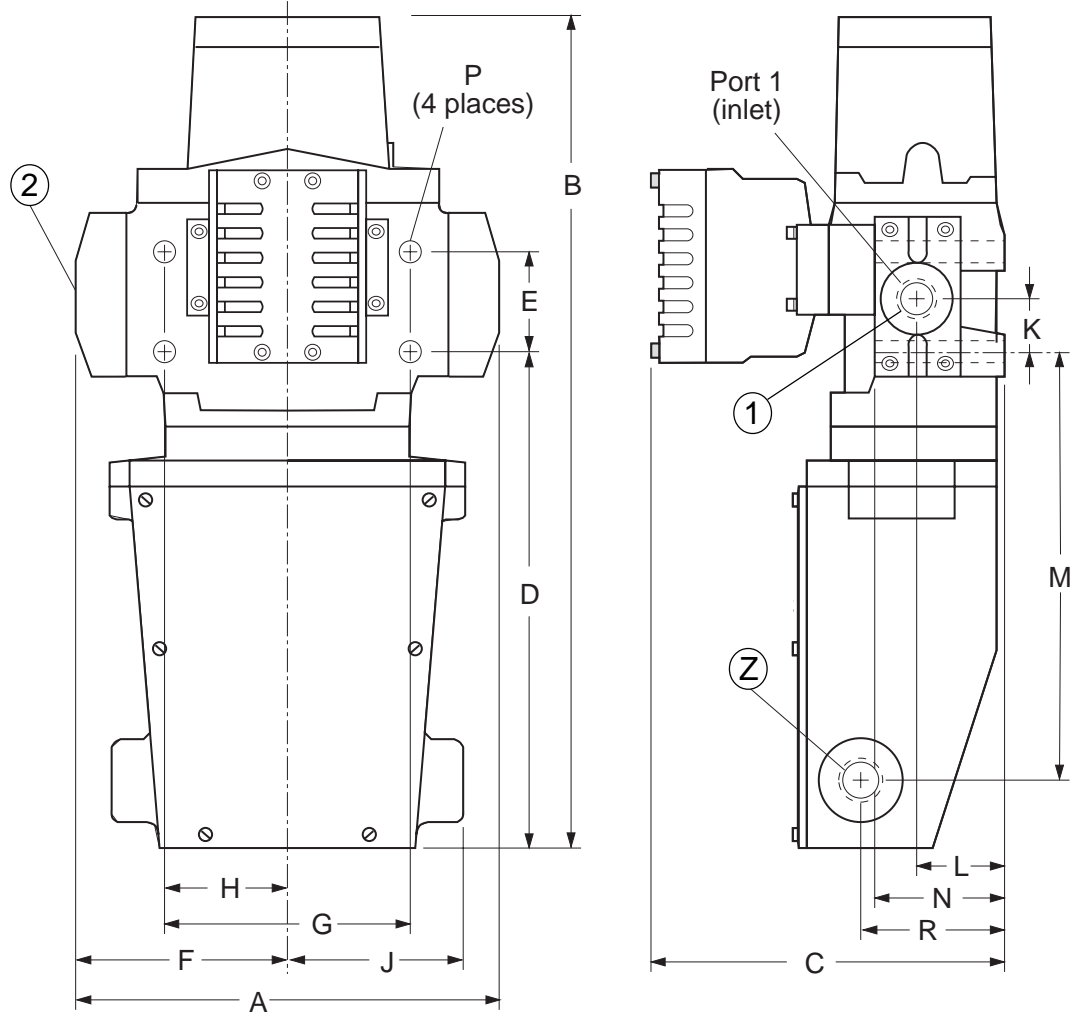

PIPING FLANGE KITS

Each kit includes two threaded (NPT) flanges and the required seals and mounting bolts. Order by the following kit numbers:

Nominal Size	Port Size	Kit Number
8	1/2	661K77
	3/4	662K77
	1	663K77
12	3/4	664K77
	1	665K77
	1-1/4	666K77
30	1-1/4	667K77
	1-1/2	668K77

DIMENSIONS inches (mm)

①	②	1/2, 3/4, 1	3/4, 1, 1-1/4	3/4, 1, 1-1/4
②	1/2 NPSC electrical opening			
A		8.52 (216)	8.96 (228)	12.36 (314)
B		16.5 (418)	17.8 (451)	21.8 (553)
C		9.9 (184)	10.3 (262)	9.7 (245)
D		4.7 (252)	5.0 (127)	5.1 (130)
E		2.10 (53.3)	3.0 (76.2)	5.90 (150)
F		4.26 (108)	4.48 (114)	6.18 (157)
G		5.06 (128)	5.50 (140)	8.56 (217)
H		2.53 (64)	2.75 (70)	4.28 (109)
J		3.42 (87)	3.42 (87)	3.42 (87)
K		1.25 (32)	1.81 (46)	4.52 (115)
L		1.80 (46)	1.69 (43)	2.27 (58)
M		8.81 (224)	9.18 (233)	8.53 (217)
N		2.6 (66)	3.0 (76)	3.7 (93)
P		0.28 (7.1)	0.34 (8.7)	0.53 (13.5)
R		2.70 (69)	2.70 (69)	3.06 (78)

SERPAR® Crossflow Double Valves

with & without Pressure Switches** (Non-Monitored) Sizes 1 & 2



Crossflow Size 1

Crossflow Size 2

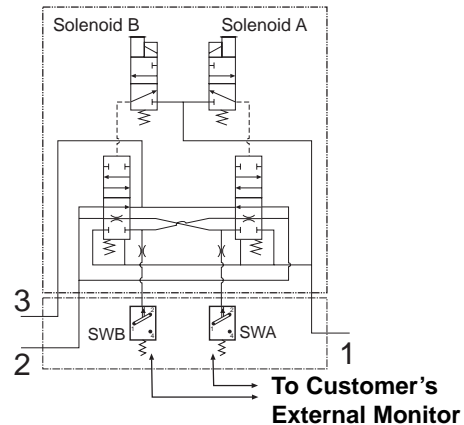

STANDARD SPECIFICATIONS

- Pilot Solenoids:** Two, rated for continuous duty.
- Standard Voltages:** 100-110 volts 50 Hz; 100-120 volts 60 Hz; 24, 110 volts d.c. Other voltages available.
- Size 1- Power Consumption:** Each solenoid. 12 VA inrush, 9.8 VA (max) holding on 50 or 60 hertz; 7.5 watts (max) on DC.
- Size 2- Power Consumption:** Each solenoid. 11 VA inrush, 8.5 VA (max) holding on 50 or 60 hertz; 6.0 watts (max) on DC.
- Electrical Connections:** Uses two cord-grip connectors at solenoids. Order separately from page 17.
- Ambient Temperature:** 40° to 120° F (4° to 50°C).
- Media Temperature:** 40° to 175° F (4° to 80°C).
- Flow Media:** Filtered Air.
- Inlet Pressure:** 40 to 100 psig (2.8 to 7 bar).

OPTIONS

- Valve Without Piping Flanges:** See below.
- Valve Without Silencer:** Exhaust port has threaded flange only. Consult ROSS.

$$\text{Valve Response Time (msec)} = M + F \cdot V$$

See *Valve Response Time* and Cv ratings on page 18.

VALVE OPERATION

Both solenoids must be energized simultaneously to shift the valve; maintained signal required to keep valve shifted. **WARNING: If a monitor must be reset, electrical signals to both solenoids must be removed to prevent the machine controlled by the valve from immediately recycling and producing a potentially hazardous condition.**

IMPORTANT NOTE: Please read carefully and thoroughly all of the CAUTIONS on page 19.

****PRESSURE SWITCHES & MONITORING**
Valves without pressure switches must not be used to control clutch/brake mechanisms on press machinery. Valves with pressure switches must be used in conjunction with an external monitoring device to assist with OSHA compliance (Ref. 1910.217). The valves on this page do not have a built-in monitor, and so must only be used in conjunction with an external monitoring system. Such monitoring system must be capable of inhibiting the operation of the valve and associated machinery in the event of a failure within the valve.

Valve Size	Model Numbers*	Pressure Switches**	Pressure Switch Provision	Port Sizes 1 & 2 3			Avg. Response Constants			Weight lbs (kg)
							M	F		
								1 to 2	2 to 3	
1	3573B2632	None	Yes	1/4	1/4	28	4.6	3.4	2.1 (.95)	
	3573B2640	None	No	1/4	3/8	24	4.4	3.1	2.1 (.95)	
	3573B2642	Two	Yes	1/4	1/4	28	4.6	3.4	2.5 (1.14)	
	3573B2644	Two	Yes	3/8	3/8	25	3.1	2.8	2.9 (1.32)	
	3573B2645	None	Yes	3/8	3/8	25	3.1	2.8	2.5 (1.14)	
2	3573B4620	None	No	1/2	1/2	30	1.2	1.0	4.3 (1.95)	
	3573B4632	None	Yes	1/2	1/2	30	1.2	1.0	4.3 (1.95)	
	3573B4640	None	No	1/2	3/4	25	1.1	0.9	4.3 (1.95)	
	3573B4642	Two	Yes	1/2	1/2	30	1.2	1.0	4.8 (2.18)	
	3573B4643	None	No	3/4	3/4	25	1.1	0.9	4.7 (2.13)	
	3573B4644	Two	Yes	3/4	3/4	25	1.1	0.9	5.2 (2.36)	
	3573B4645	None	Yes	3/4	3/4	25	1.1	0.9	4.7 (2.13)	
3573B4652	None	Yes	1/2	3/4	25	1.1	0.9	4.3 (1.95)		

* Model number includes base. For G threads, order bases with a "D" prefix. For JIS threads, order bases with a "J" prefix. Valve and base can be ordered separately; see page 17.



ELECTRICAL CONNECTORS

Electrical connectors are required to connect the valve solenoids to the drop cords supplying electrical power. Each connector can be positioned so that the cord exits upward or to the side. Cords of 6-mm to 10-mm diameter can be used.

Connectors with a light in a translucent housing are also available to serve as indicator lights. Order connectors by the part numbers given in the chart below.

WIRED CONNECTORS have a 2-meter (6-1/2 ft.) cord with three 18-gauge conductors. Cord exits upward, and is available in either 6-mm or 10-mm diameter.

CONNECTORS for THREADED CONDUIT accept 1/2-inch electrical conduit fittings.

Size 1- Part Numbers of Electrical Connectors

Connector Type	Without Light	With Light*
For use with dropcord (cord not included)	266K77	267K77
Wired with 10-mm cord (cord exits upward)	372K77	382K77

Size 2- Part Numbers of Electrical Connectors

For use with dropcord (Cord not included)	937K87	936K87
Wired with 6-mm cord	721K77	720K77
Wired with 10-mm cord	371K77	383K77
For use with threaded conduit	723K77	724K77

*Specify solenoid voltage.

VALVE DIMENSIONS inches (mm)

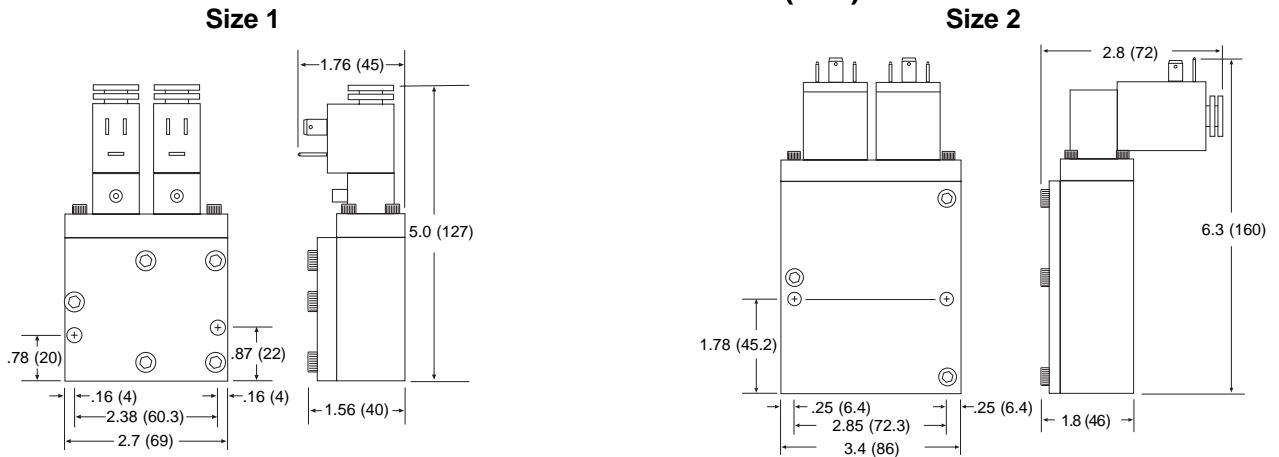

BASE DIMENSIONS inches (mm)

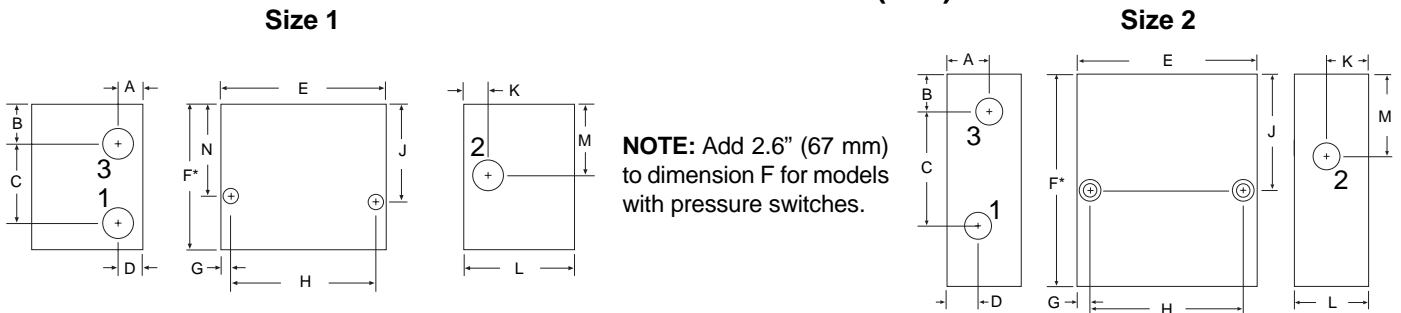

Model #	Base	A	B	C	D	E	F	G	H	J	K	L	M	N
3573B2632	1120C91	0.4 (11)	0.7 (17)	1.29 (32.8)	0.4 (11)	2.7 (69)	2.4 (61)	0.2 (5)	2.38 (60.5)	1.6 (41)	0.4 (11)	1.8 (46)	1.2 (30)	1.5 (38)
3573B2640	1042C91	0.5 (13)	0.6 (15)	1.36 (34.5)	0.4 (11)	2.7 (69)	2.4 (61)	0.2 (5)	2.38 (60.5)	1.6 (41)	0.4 (11)	1.8 (46)	1.2 (30)	1.5 (38)
3573B2642	888C91	0.4 (11)	0.7 (17)	1.29 (32.8)	0.4 (11)	2.7 (69)	2.4 (61)	0.2 (5)	2.38 (60.5)	1.6 (41)	0.4 (11)	1.8 (46)	1.2 (30)	1.5 (38)
3573B2644	1171C91	0.5 (13)	0.6 (15)	1.47 (37.2)	0.5 (13)	2.7 (69)	2.5 (63)	0.2 (5)	2.38 (60.5)	1.6 (41)	0.8 (19)	1.8 (46)	1.1 (27)	1.5 (38)
3573B2645	1172C91	0.5 (13)	0.6 (15)	1.47 (37.2)	0.5 (13)	2.7 (69)	2.5 (63)	0.2 (5)	2.38 (60.5)	1.6 (41)	0.8 (19)	1.8 (46)	1.1 (27)	1.5 (38)
3573B4620	1136C91	0.8 (19)	0.7 (17)	2.15 (54.6)	0.6 (15)	3.4 (86)	4.0 (101)	0.3 (7)	2.85 (72.4)	2.2 (56)	0.8 (19)	1.4 (36)	1.6 (39)	—
3573B4632	1122C91	0.8 (19)	0.7 (17)	2.15 (54.6)	0.6 (15)	3.4 (86)	4.0 (101)	0.3 (7)	2.85 (72.4)	2.2 (56)	0.8 (19)	1.4 (36)	1.6 (39)	—
3573B4640	1028C91	1.1 (27)	1.0 (24)	2.32 (58.9)	0.6 (15)	3.4 (86)	4.3 (110)	0.3 (7)	2.85 (72.4)	2.6 (64)	0.8 (19)	1.7 (44)	1.9 (48)	—
3573B4642	893C91	0.8 (19)	0.7 (17)	2.15 (54.6)	0.6 (15)	3.4 (86)	4.0 (101)	0.3 (7)	2.85 (72.4)	2.2 (56)	0.8 (19)	1.4 (36)	1.6 (39)	—
3573B4643	1123C91	1.1 (27)	0.8 (19)	2.64 (67.1)	1.3 (33)	3.7 (94)	4.3 (110)	0.3 (7)	2.85 (72.4)	2.6 (64)	0.7 (17)	2.0 (50)	1.8 (46)	—
3573B4644	1163C91	1.1 (27)	0.8 (19)	2.86 (72.7)	0.7 (17)	3.7 (94)	4.3 (110)	0.3 (7)	2.85 (72.4)	2.6 (64)	0.7 (17)	2.0 (50)	1.8 (46)	—
3573B4645	1164C91	1.1 (27)	0.8 (19)	2.86 (72.7)	0.7 (17)	3.7 (94)	4.3 (110)	0.3 (7)	2.85 (72.4)	2.6 (64)	0.7 (17)	2.0 (50)	1.8 (46)	—
3573B4652	1129C91	1.1 (27)	1.0 (24)	2.32 (58.9)	0.6 (15)	3.4 (86)	4.3 (110)	0.3 (7)	2.85 (72.4)	2.6 (64)	0.8 (19)	1.7 (44)	1.9 (48)	—

For replacement valve (less base): Size 1 – order model 3573B2602; Size 2 – order model 3573B4602.



VALVE RESPONSE TIME and C_v RATINGS

VALVE RESPONSE TIMES

Most pneumatic applications call for a valve to be used to control the repeated filling and exhausting device (cylinder, clutch, etc.) having a certain volume. The time required to fill or exhaust this volume is called the "valve response time."

The time to fill a volume is usually different from the time to exhaust the volume. However, both times can be found using the following formula:

$$\text{Valve Response Time (msec)} = M + F \cdot V$$

This formula will give the number of milliseconds (msec) required to fill the volume V to 90 percent of supply pressure or to exhaust the volume to 10 percent of supply pressure. M and F are *average response constants*, and their values for each valve are given on the valve specification pages (8-17). V is the number of cubic inches in the volume to be filled or exhausted. Response times will be valid for any supply pressure from 3.5 to 8.5 bar (50 to 125 psig).

What is the constant M? When a valve is energized, it takes a number of milliseconds for the valve to shift and allow a steady flow of air to be established at the outlet port. In a like manner, when the valve is deenergized, it takes a number of milliseconds for the valve to cut off the flow of air and establish the flow of exhaust air. These valve "movement" times are designated by M in the above formula.

What is the constant F? After the valve has shifted and air flow (either to fill or exhaust) is established, the air flows rapidly at first, then flows at a reducing rate. The *average flow rate* is represented in the above formula by the letter F. It is the average number of milliseconds required to fill or exhaust one cubic inch of the volume V. The product F • V, then, is the average number of milliseconds required to fill or exhaust the entire volume V after the valve has shifted.

Sample Problem. How long will it take to fill a 100-cubic-inch clutch to 90 percent of supply pressure using a nominal size 8 double valve with 3/4 ports?

Solution. Specifications for size 8 valves are given on pages 10, 12, and 14. From the chart on page 10 (pages 12 and 14 will give the same values) we find that the average response constants for a size 8 valve with 3/4 ports are M = 15 and F = 0.65. The F value of 0.23 is for the exhausting paths and is not needed for this problem. Putting the M and F values into the response time formula gives:

$$\begin{aligned} \text{Average response time} &= 15 + (0.65)(100) \\ &= 15 + 65 \\ &= 80 \text{ msec} \end{aligned}$$

Therefore, the 100-cubic-inch volume would be filled to 90 percent of supply pressure in just 80 milliseconds.

AVERAGE C_v RATINGS

Because widely differing test standards are used in the measurement of C_v values, the following figures should not be used in comparing ROSS valves with other makes. These C_v ratings are intended only for use with performance charts published by ROSS.

Nominal Size	Port Size	Average C _v Ratings	
		1 to 2	2 to 3
1	1/4	0.9	1.4
	3/8	1.2	1.7
2	1/2	3.7	6.6
	3/4	4.2	9.0
4	3/8	3.0	7
	1/2	3.0	9
	3/4	3.0	11
8	1/2	3.5	10
	3/4	4.0	14
	1	4.0	14
12	3/4	8.0	15
	1	8.5	19
	1-1/4	9.0	21
30	1-1/4	20	42
	1-1/2	21	43

THREAD OPTIONS

To serve customers around the world, ROSS supplies double valves with threaded pressure ports and electrical openings that conform to various local standards. These variations are identified by a letter preceding the valve model number or flange kit number. The specifications for these prefix letters are shown in the chart at the right.

Prefix Letter	Pneumatic Port Threads	Electrical Opening	
		L-G or E-P Monitor	D-S Monitor
None	NPT	1/2 NPSC	3/4 NPSC
D	DIN 259, BSPP (parallel)	R 1/2	R 3/4
J	JIS B0203 (tapered)	PF 1/2	PF 3/4

CAUTIONS

PRE-INSTALLATION or SERVICE

1. Before servicing a valve or other pneumatic component, be sure that the electrical supply is turned off, the entire pneumatic system is shut off and exhausted, and all power sources are locked out.
2. All ROSS products, including service kits and parts, should be installed and/or serviced only by persons having training and experience with pneumatic equipment. Because any installation can be tampered with or need servicing after installation, persons responsible for the safety of others or the care of equipment must check every installation on a regular basis and perform all necessary maintenance.
3. All applicable instructions should be read and complied with before using any fluid power system in order to prevent harm to persons or equipment. In addition, overhauled or serviced valves must be functionally tested prior to installation and use.
4. Each ROSS product should be used within its specification limits. In addition, use only ROSS parts to repair ROSS products. Failure to follow these directions can adversely affect the performance of the product or result in the potential for human injury.

FILTRATION and LUBRICATION

5. Dirt, scale, moisture, etc. are present in virtually every air system. Although some valves are more tolerant of these contaminants than others, best performance will be realized if a filter is installed to clean the air supply, thus preventing contaminants from interfering with the proper performance of the equipment. ROSS recommends a filter with a 5-micron rating for normal applications.
6. All standard ROSS filters and lubricators with polycarbonate plastic bowls are designed for compressed air applications only. Do *not* fail to use the metal bowl guard, where provided, to minimize danger from high pressure fragmentation in the event of bowl failure. Do not expose these products to certain fluids, such as alcohol or liquified petroleum gas, as they can cause bowls to rupture, creating a combustible condition, hazardous leakage, and the potential for human injury. Immediately replace a crazed, cracked, or deteriorated bowl. When bowl gets dirty, replace it or wipe it with a clean dry cloth.

7. Only use lubricants which are compatible with materials used in the valves and other components in the system. Normally, compatible lubricants are petroleum base oils with oxidation inhibitors, an aniline point between 82 degrees Celsius (180 degrees Fahrenheit) and 104 degrees Celsius (220 degrees Fahrenheit), and an ISO 32, or lighter, viscosity. Avoid oils with phosphate type additives which can harm polyurethane components, potentially leading to valve failure and/or human injury.

AVOID INTAKE/EXHAUST RESTRICTION

8. Do not restrict the air flow in the supply line. To do so could reduce the pressure of the supply air below the minimum requirements for the valve and thereby cause erratic action.
9. Do not restrict a poppet valve's exhaust port as this can adversely affect its operation. Exhaust silencers must be resistant to clogging and have flow capacities at least as great as the exhaust capacities of the valves. Contamination of the silencer can result in reduced flow and increased back pressure. *ROSS expressly disclaims all warranties and responsibility for any unsatisfactory performance or injuries caused by the use of the wrong type, wrong size, or inadequately maintained silencer installed with a ROSS product.*

POWER PRESSES

10. Mechanical power presses and other potentially hazardous machinery using a pneumatically controlled clutch and brake mechanism must use a press control double valve with a monitoring device. A double valve without a self-contained monitoring device should be used only in conjunction with a control system which assures monitoring of the valve. All double valve installations involving hazardous applications should incorporate a monitoring system which inhibits further operation of the valve and machine in the event of a failure within the valve mechanism.

ENERGY ISOLATION/EMERGENCY STOP

11. Per specifications and regulations, ROSS' **L-O-X®** and **L-O-X/EEZ-ON®** products are defined as energy isolation devices, NOT AS EMERGENCY STOP DEVICES.

WARRANTY

Products manufactured by ROSS are warranted to be free of defects in material and workmanship for a period of one year from the date of purchase. ROSS' obligation under this warranty is limited to repair or replacement of the product or refund of the purchase price paid solely at the discretion of ROSS and provided such product is returned to ROSS freight prepaid and upon examination by ROSS such product is found to be defective. This warranty shall be void in the event that product has been subject to misuse, misapplication, improper maintenance, modification or tampering. THE WARRANTY EXPRESSED ABOVE IS IN LIEU OF AND EXCLUSIVE OF ALL OTHER WARRANTIES AND ROSS EXPRESSLY DISCLAIMS ALL OTHER WARRANTIES EITHER EXPRESSED OR IMPLIED WITH RESPECT TO MERCHANTABILITY OR FITNESS FOR A PARTICULAR PURPOSE. ROSS MAKES NO WARRANTY WITH RESPECT TO ITS PRODUCTS MEETING THE PROVISIONS OF ANY GOVERNMENTAL OCCUPATIONAL SAFETY AND/OR HEALTH LAWS OR REGULATIONS. IN NO EVENT SHALL ROSS BE LIABLE TO PURCHASER, USER, THEIR EMPLOYEES OR OTHERS FOR INCIDENTAL OR CONSEQUENTIAL DAMAGES WHICH MAY RESULT FROM A BREACH OF THE WARRANTY DESCRIBED ABOVE OR THE USE OR MISUSE OF THE PRODUCTS. NO STATEMENT OF ANY REPRESENTATIVE OR EMPLOYEE OF ROSS SHALL EXTEND THE LIABILITY OF ROSS AS SET FORTH HEREIN.





ROSS CONTROLS®

P.O. Box 7015

Troy, Michigan 48007 U.S.A.

Telephone (00) 1-248-764-1800

Fax (00) 1-248-764-1850

www.rosscontrols.com

In the United States:

Customer Service- 1-800-GET-ROSS

Technical Service- 1-888-TEK-ROSS

ROSS/FLEX® Service- 1-888-ROSS-FLX

ROSS UK Ltd.

St. James Road, Brackley

Northamptonshire NN13 7XY

United Kingdom

Telephone (011) 44-1280-706668

Fax (011) 44-1280-705630

ROSS EUROPA GmbH

Robert-Bosch-Straße 2

D-63225 Langen, Germany

Telephone (011) 49-6103-7597-0

Fax (011) 49-6103-7469-4

ROSS ASIA K.K.

10209-5 Tana, Sagami-hara-shi

Kanagawa 229-1124, Japan

Telephone (011) 81-427-78-7251

Fax (011) 81-427-78-7256

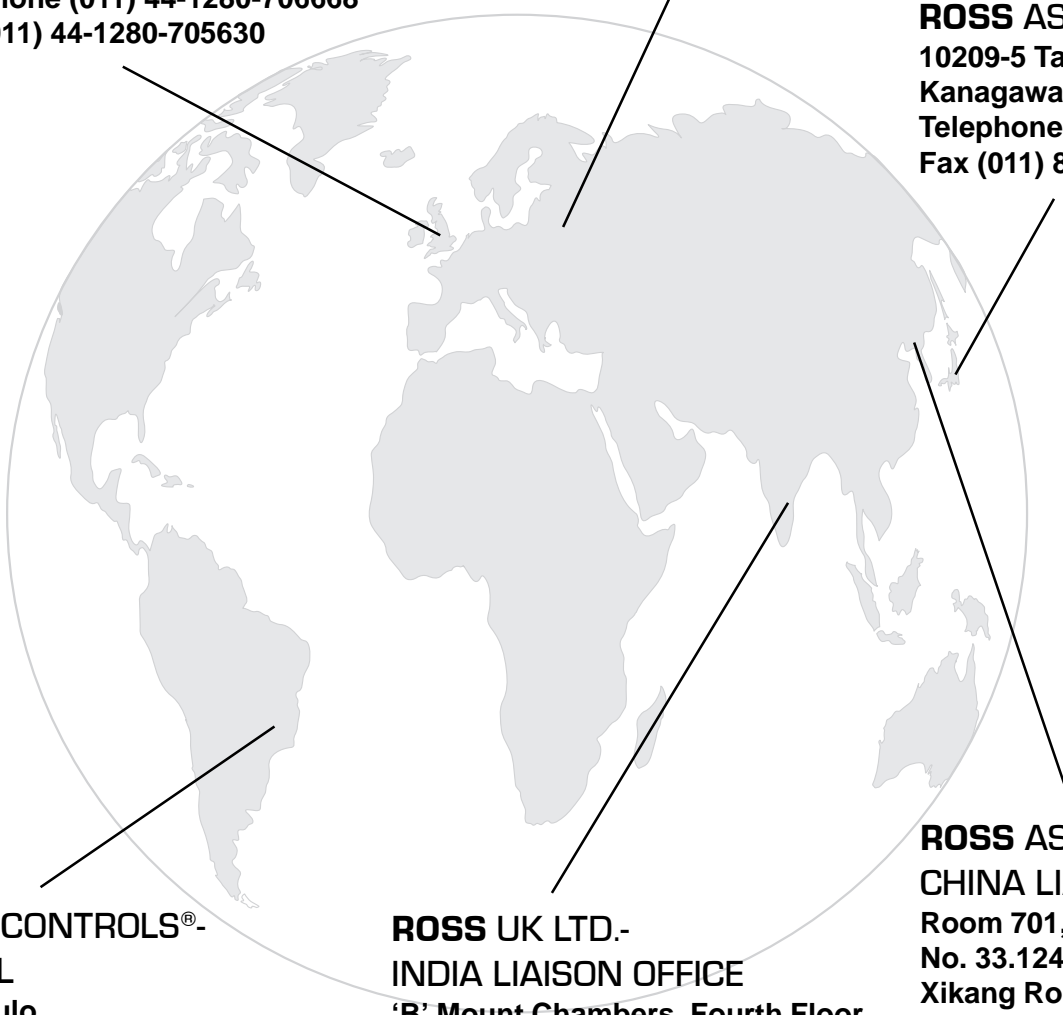

ROSS CONTROLS®-

BRAZIL

São Paulo

Telephone (011) 55-11-9916-3296

ROSS UK LTD.-

INDIA LIAISON OFFICE

'B' Mount Chambers, Fourth Floor

758 Mount Road

Chennai, 600 002 India

Telephone (011) 91-44-841-3136

Fax (011) 91-44-841-3137

ROSS ASIA K.K.-

CHINA LIAISON OFFICE

Room 701, Taiji Building,

No. 33.1249 Street

Xikang Road

Shanghai, China

Telephone (011) 021-6296-5123

Fax (011) 021-6299-0529