



**BULLETIN 505**

**DM<sup>2</sup>™ Crossflow™ SERPAR®**  
**3/2 Double Valves**  
with  
**TOTAL Dynamic Monitoring & Memory**



U.S. Patent Numbers 6840258, 6840259  
and worldwide patents pending

**A Worldwide Leader in Double Valve Technology Since 1950**

# DM<sup>2</sup>™ Crossflow™ SERPAR® Double Valves

The ROSS DM<sup>2</sup>™ Crossflow™ SERPAR® double valves provide new features in response to the changing demands of the mechanical press industry and its associated standards (e.g. EN 692 ff.) and regulations regarding the control of pneumatically controlled clutch and brake applications. The consensus requirements of the regulations and good practices require that, in case of a failure within the valve, the clutch and brake mechanisms be quickly exhausted, a monitor takes action to prevent further operation, and a method to alert personnel is incorporated. These new features also make the valve suitable for use in other Category -3 & -4 safety-related applications.

A ROSS DM<sup>2</sup>™ double valve has two valve elements independently controlled by two solenoid pilots. The two valve elements share common inlet, outlet, and exhaust ports. When the pilot valves are simultaneously energized, the valve elements operate so that the valve functions as a 3/2 normally closed valve.

If one of the valve elements does not open or close synchronously (see Lock-outs, pg 17) with the other, the valve is designed to keep the pressure in the outlet port at less than 1 percent of

inlet pressure. This is an inherent safety characteristic of the ROSS DM<sup>2</sup>™ design. Valve element redundancy provides a safety factor, as the likelihood of a malfunction in both valve elements in the same cycle is considered extremely remote.

DM<sup>2</sup>™ valves also have an internal monitor that is integrated into the valve elements. Should the valve operate abnormally, the monitor will prevent further valve operation until corrective action is taken.

**IMPORTANT NOTE:** Standards, regulations, and good practice all require that mechanical power presses or other hazardous machines using a pneumatically-controlled clutch and brake mechanism be equipped with a double valve with a self-contained monitoring device and/or an external monitoring system, which inhibits further operation of the valve and machine in the event of a failure within the valve. Of course, a double valve is just one of the components in a press control system, and all other elements of the system should be planned with safety as a primary consideration.

**DM<sup>2</sup>™ Monitoring:** The DM<sup>2</sup>™ is a patented 3/2 normally closed valve (with an intermediate, lock-out position) distinguished by Crossflow® passages with poppet and spool valving on the main valve stems. This arrangement provides the valve's outstanding flow characteristics and an integrated monitoring capability with TOTAL memory. The valve provides:

## DYNAMIC MONITORING and DYNAMIC MEMORY.

**DYNAMIC MONITORING** means that all monitoring components change state on every valve cycle. Should the valve elements cycle asynchronously, the valve will lock out. **DYNAMIC MEMORY** is a monitoring system that locks out the valve, to prevent further operation, whenever the valve elements cycle asynchronously (see Lock-outs, pg 17) either on actuation or de-actuation. The DM<sup>2</sup>™ system can only be reset by a defined operation, and will not self-reset or reset when inlet air supply is removed and re-applied. Such automatic resetting would conceal potential hazards from the operator.

**Valve Sizes:** DM<sup>2</sup>™ valves are available in 4 sizes, providing a broad range of flow capabilities to meet your needs. For convenience, valves are designated by the nominal sizes 4, 8, 12, and 30 with outlet ports up to 1/2, 3/4, 1, 1-1/2, and 2 respectively. Response curves are provided on page 13.

## The Leader in Double Valve Design

ROSS has long been in the forefront of double valve research and development. For over 55 years ROSS has been responding to the needs of press manufacturers and users by progressively improving double valve technology. Internal flow patterns of double valves developed by ROSS have included series flow, parallel flow, combined series-parallel tandem flow, and combined series-parallel Crossflow™.

Monitoring devices have also been offered in a variety of designs to satisfy differing requirements. Traditionally, in order to achieve complete monitoring capability, it has been necessary to add devices or components to the valve or to the control system. The new DM<sup>2</sup>™ valve combines the monitor and the main valve components into two identical piston-poppet assemblies. Utilizing two piston-poppet assemblies provides a redundant 3/2 normally closed air flow pattern, dynamic monitoring, and dynamic memory.

During valve operation air pressure acting on changing combinations of assembly surfaces cause the assemblies to move to the required position. Force balances in the valve assure positive shifting forces during normal operation as well as a positive force to hold the assemblies in a locked-out position.

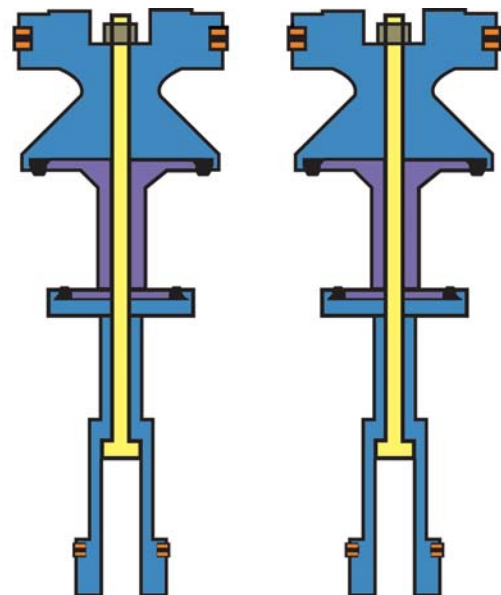

# Overview of **DM<sup>2</sup>**™ Double Valve Function

(Please refer to the Main Valve Internals illustration on pg. 16.)

The flow of inlet air pressure into the crossover passages is restricted by the size of the passage between the stem and the valve body opening. Flow is sufficient to quickly pressurize pilot supply/timing chambers A and B. The inlet poppets prevent air flow from crossover passages into the outlet chamber. Air pressure acting on the inlet poppets and return pistons securely hold the valve elements in the closed position. (Air passages shown out of position and reset adapter omitted for clarity.)

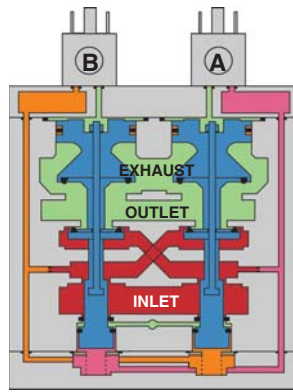

**Valve ready to run.**

Energizing the pilot valves simultaneously applies pressure to both pistons, forcing the internal parts to move to their actuated (open) position, where inlet air flow to crossover passages is fully open, inlet poppets are fully open and exhaust poppets are fully closed. The outlet is then quickly pressurized, and pressure in the inlet, crossovers, outlet, and timing chambers are quickly equalized.

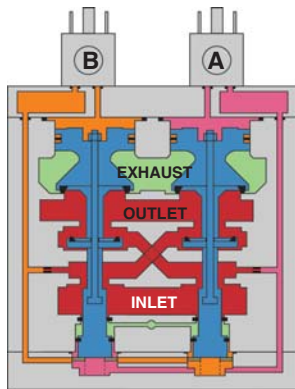

**Valve actuated.**

De-energizing the pilots quickly causes the valve elements to return to the ready-to-run position.

Whenever the valve elements operate in a sufficiently asynchronous manner, either on actuation or de-actuation, the valve will move to a locked-out position. In the locked-out position, one crossover and its related timing chamber will be exhausted, and the other crossover and its related timing chamber will be fully pressurized. The valve element (side B) that is partially actuated has pilot air available to fully actuate it, but no air pressure on the return piston to fully de-actuate the valve element. Air pressure in the crossover acts on the differential of side B stem diameters creating a latching force.

Side A is in a fully closed position, and has no pilot air available to actuate, but has full pressure on the inlet poppet and return piston to hold the element in the fully closed position. Inlet air

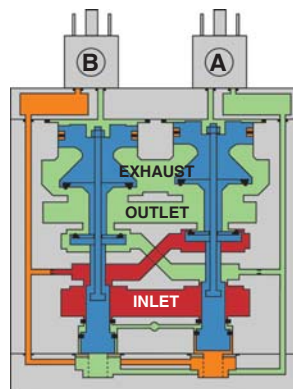

**Valve locked out.**

flow on side A into its crossover is restricted, and flows through the open inlet poppet on side B, through the outlet into the exhaust port, and from the exhaust port to atmosphere. Residual pressure in the outlet is less than 1% of inlet pressure.

The return springs are limited in travel, and can only return the valve elements to the intermediate (locked-out) position. Sufficient air pressure acting on the return pistons is needed to return the valve elements to a fully closed position.

The valve will remain in the locked-out position, even if the inlet air supply is removed and re-applied. A remote reset signal must be applied to reset the valve.

Reset is accomplished by momentarily pressurizing the reset port. Actuation of the reset piston physically pushes the main valve elements to their closed position. Inlet air fully pressurizes the crossovers and holds the inlet poppets on seat. Actuation of the reset piston opens the reset poppet, thereby, immediately exhausting pilot supply air, thus, preventing valve operation during reset. (Reset adapter added to illustration.)

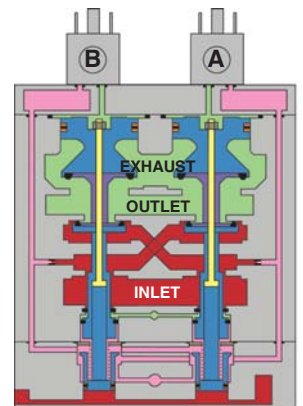

**Valve being reset.**

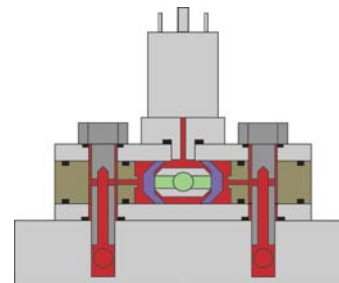

**Status indicator (optional) in normal ready to run position.**

De-actuation of reset pistons causes the reset poppets to close and pilot supply to fully pressurize.

Reset pressure can be applied by a remote 3/2 normally closed valve, or from an optional 3/2 normally closed solenoid mounted on the reset adapter.

The status indicator pressure switch will actuate when the main valve is operating normally, and will de-actuate when the main valve is in the locked-out position or inlet pressure is removed. This device is not part of the valve lock-out function, but, rather, only reports the status of the main valve.

Size 12 and 30 valves require relatively large pilots to actuate and de-actuate the main valve elements. In order to achieve extremely quick valve response for such large pilots, a 2-stage solenoid pilot system is incorporated into the design. This keeps the required electrical current, to operate the pilots, to a minimum.

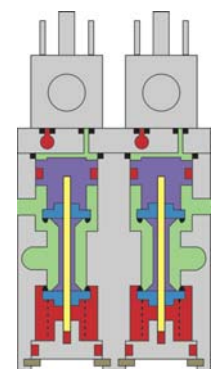

**Size 12 & 30 pilots.**

U.S. PATENT Nos. 6840258 and 6840259 – other worldwide patents pending.



Size 4

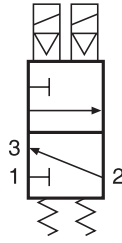

**Simplified Schematic**

(See page 14 for complete schematic.)

ROSS **DM<sup>2</sup>**™ double valves have been approved by the following testing and certifying authority: BG-PRÜFZERT, Fachausschuss "Maschinenbau, Hebezeuge, Hütten- und Walzwerksanlagen", Germany  
**Certificate Numbers: 06 008 / 06 021**

**IMPORTANT NOTE:** Please read carefully and thoroughly all of the CAUTIONS on page 16.

- **Total Dynamic Monitoring With Complete Memory:** Memory, monitoring, and air flow control functions are simply integrated into two identical valve elements. Valves lock out due to asynchronous movement of valve elements during actuation or de-actuation, resulting in a residual outlet pressure of less than 1% of supply. Overt action is required for reset – cannot be reset by removing and re-applying supply pressure. Reset can only be accomplished by remote air signal or by optional integrated electrical (solenoid) reset.
- **Basic 3/2 Normally Closed Valve Function:** Dirt tolerant, wear compensating poppet design for quick response and high flow capacity. Teflon® back-up rings on pistons to enhance valve endurance – operates with or without inline lubrication.
- **Status Indicator (Optional):** Includes a pressure switch with both N.O. & N.C. contacts to provide status feedback to the press control system indicating whether the valve is in the lock-out or ready-to-run condition. The Status Indicator can be ordered installed or purchased separately and added to any **DM<sup>2</sup>**™ base.
- **Silencers:** All models include high flow, clog resistant silencers.
- **Mounting:** Base mounted – with BSPP or NPT pipe threads. Inlet and outlet ports on both sides provide for flexible piping (plugs for unused ports included). Captive valve-to-base mounting screws.

## TECHNICAL SPECIFICATIONS

**Pilot solenoid:** According to VDE 0580. Rated for continuous duty.

**Standard voltages:** 24 VDC, 110 VAC (50/60 Hz), 220\*\* VAC (50/60 Hz). For other voltages consult ROSS. Specify voltage and frequency on order.

**Power consumption for primary and reset solenoids (each solenoid):** 5.8 W on DC; 15.8 VA inrush and 12.8 VA holding on AC.

**Enclosure rating:** IP65, IEC 60529.

**Electrical connection:** DIN 43650, Form A. Order connectors separately. See page 12.

**Ambient temperature:** 15 to 122° F (-10 to 50°C).

**Media temperature:** 40 to 175° F (4 to 80°C).

**Flow Media:** Compressed air, filtered (5µm recommended), lubricated or unlubricated (mineral oils according to DIN 51519/ISO-VG, viscosity classes 32-46).

**Inlet Pressure:** 30 to 120 psig (2 to 8 bar).

**Monitoring:** dynamically, cyclically, internally during each actuating and de-actuating movement. Monitoring function has memory and requires an overt act to reset unit after lock-out.

**Valve weight:** remote reset - 5.1 lbs (2.3 kg). Add 0.3 lbs (0.14 kg) for solenoid reset.

**Mounting orientation:** preferably horizontally (valve on top of base) or vertically (with pilot solenoids on top).

## HOW TO ORDER

(Choose your options (in red) to configure your valve model number. See pages 7, 9, & 11 for other basic sizes.)

<b>PRODUCT</b>	DM2D	D	A	4	2	A	1	1	<b>STATUS INDICATOR</b>
<b>THREAD</b>		D	N	X					1.....YES X.....NO
BSP		D	N	X					
NPT		D	N	X					
N/A (no base)		D	N	X					
<b>REVISION LEVEL</b>									<b>RESET TYPE</b>
									1.....REMOTE 2.....SOLENOID
<b>BASIC SIZE</b>									<b>VOLTAGE</b>
4.....									A.....24 VDC B.....110 VAC C**.....220 VAC
<b>BASE PORT SIZE</b>									
1/2 inlet – 1/2 outlet.....									
1/2 inlet – 3/4 outlet.....									
Valve only (less base).....									

\*\* 220 VAC not available in the U.S. (OSHA regulations limit press control voltage to no more than 120 VAC.)

## BASE MODEL NUMBERS and BASE SPECIFIC INFORMATION

Model Number*	Inlet Port	Outlet Port	Status Indicator	Weight lbs (kg)
1697C91	1/2	1/2	No	1.7 (0.8)
1698C91	1/2	1/2	Yes	2.3 (1.1)
1699C91	1/2	3/4	No	1.7 (0.8)
1700C91	1/2	3/4	Yes	2.3 (1.1)

\*NPT port threads. For BSP threads add a "D" prefix to the model number. For example, D1700C91.

## DIMENSIONS – inches (mm)

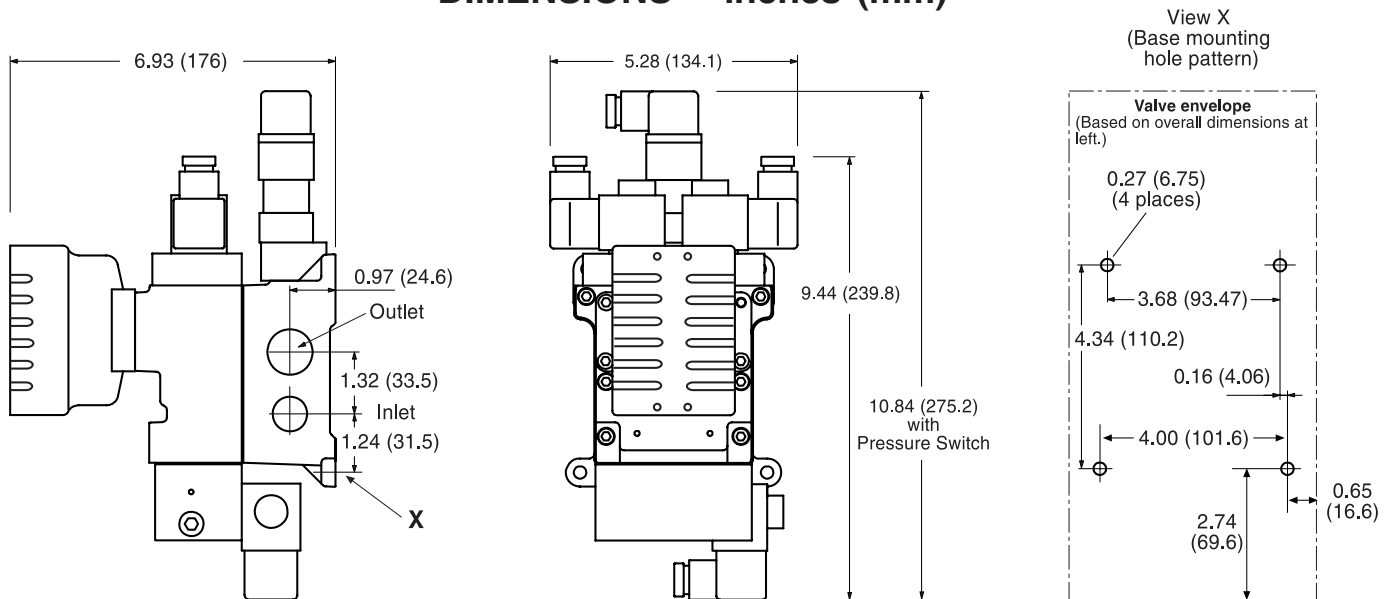

U.S. PATENT Nos. 6840258 and 6840259 – other worldwide patents pending.



Size 8

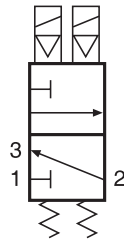

**Simplified Schematic**  
(See page 14 for complete schematic.)

ROSS **DM<sup>2</sup>**™ double valves have been approved by the following testing and certifying authority: BG-PRÜFZERT, Fachausschuss "Maschinenbau, Hebezeuge, Hütten- und Walzwerksanlagen", Germany  
**Certificate Numbers: 06 008 / 06 021**

**IMPORTANT NOTE:** Please read carefully and thoroughly all of the CAUTIONS on page 16.

- **Total Dynamic Monitoring With Complete Memory:** Memory, monitoring, and air flow control functions are simply integrated into two identical valve elements. Valves lock out due to asynchronous movement of valve elements during actuation or de-actuation, resulting in a residual outlet pressure of less than 1% of supply. Overt action is required for reset – cannot be reset by removing and re-applying supply pressure. Reset can only be accomplished by remote air signal or by optional integrated electrical (solenoid) reset.
- **Basic 3/2 Normally Closed Valve Function:** Dirt tolerant, wear compensating poppet design for quick response and high flow capacity. Teflon® back-up rings on pistons to enhance valve endurance – operates with or without inline lubrication.
- **Status Indicator (Optional):** Includes a pressure switch with both N.O. & N.C. contacts to provide status feedback to the press control system indicating whether the valve is in the lock-out or ready-to-run condition. The Status Indicator can be ordered installed or purchased separately and added to any **DM<sup>2</sup>**™ base.
- **Silencers:** All models include high flow, clog resistant silencers.
- **Mounting:** Base mounted – with BSPP or NPT pipe threads. Inlet and outlet ports on both sides provide for flexible piping (plugs for unused ports included). Captive valve-to-base mounting screws.

## TECHNICAL SPECIFICATIONS

**Pilot solenoid:** According to VDE 0580. Rated for continuous duty.

**Standard voltages:** 24 VDC, 110 VAC (50/60 Hz), 220\*\* VAC (50/60 Hz). For other voltages consult ROSS. Specify voltage and frequency on order.

**Power Consumption (each solenoid):**

*Primary solenoids:* 15 W on DC; 36 VA inrush and 23 VA holding on AC.

*Reset solenoid:* 5.8 W on DC; 15.8 VA inrush and 12.8 VA holding on AC.

**Enclosure rating:** IP65, IEC 60529.

**Electrical connection:** DIN 43650, Form A. Order connectors separately. See page 12.

**Ambient temperature:** 15 to 122° F (-10 to 50°C).

**Media temperature:** 40 to 175° F (4 to 80°C).

**Flow Media:** Compressed air, filtered (5µm recommended), lubricated or unlubricated (mineral oils according to DIN 51519/ISO-VG, viscosity classes 32-46).

**Inlet Pressure:** 30 to 120 psig (2 to 8 bar).

**Monitoring:** dynamically, cyclically, internally during each actuating and de-actuating movement. Monitoring function has memory and requires an overt act to reset unit after lock-out.

**Valve weight:** remote reset - 8.2 lbs (3.7 kg). Add 0.3 lbs (0.14 kg) for solenoid reset.

**Mounting orientation:** preferably horizontally (valve on top of base) or vertically (with pilot solenoids on top).

**HOW TO ORDER**

(Choose your options (in red) to configure your valve model number. See pages 5, 9, & 11 for other basic sizes.)

<b>PRODUCT</b>	DM2D	D	A	5	4	A	1	1	<b>STATUS INDICATOR</b>
<b>THREAD</b>									1.....YES X.....NO
BSP		D							
NPT		N							
N/A (no base)		X							
<b>REVISION LEVEL</b>									<b>RESET TYPE</b>
									1.....REMOTE 2.....SOLENOID
<b>BASIC SIZE</b>									<b>VOLTAGE</b>
8.....				5					A.....24 VDC B.....110 VAC C**.....220 VAC
<b>BASE PORT SIZE</b>									
3/4 inlet – 3/4 outlet.....					4				
1 inlet – 1 outlet.....						5			
Valve only (less base).....							X		

\*\* 220 VAC not available in the U.S. (OSHA regulations limit press control voltage to no more than 120 VAC.)

**BASE MODEL NUMBERS and BASE SPECIFIC INFORMATION**

Model Number*	Inlet Port	Outlet Port	Status Indicator	Weight lbs (kg)
1701C91	3/4	3/4	No	3.6 (1.6)
1702C91	3/4	3/4	Yes	4.2 (1.9)
1703C91	1	1	No	3.6 (1.6)
1704C91	1	1	Yes	4.2 (1.9)

\*NPT port threads. For BSP threads add a "D" prefix to the model number. For example, D1701C91.

**DIMENSIONS – inches (mm)**

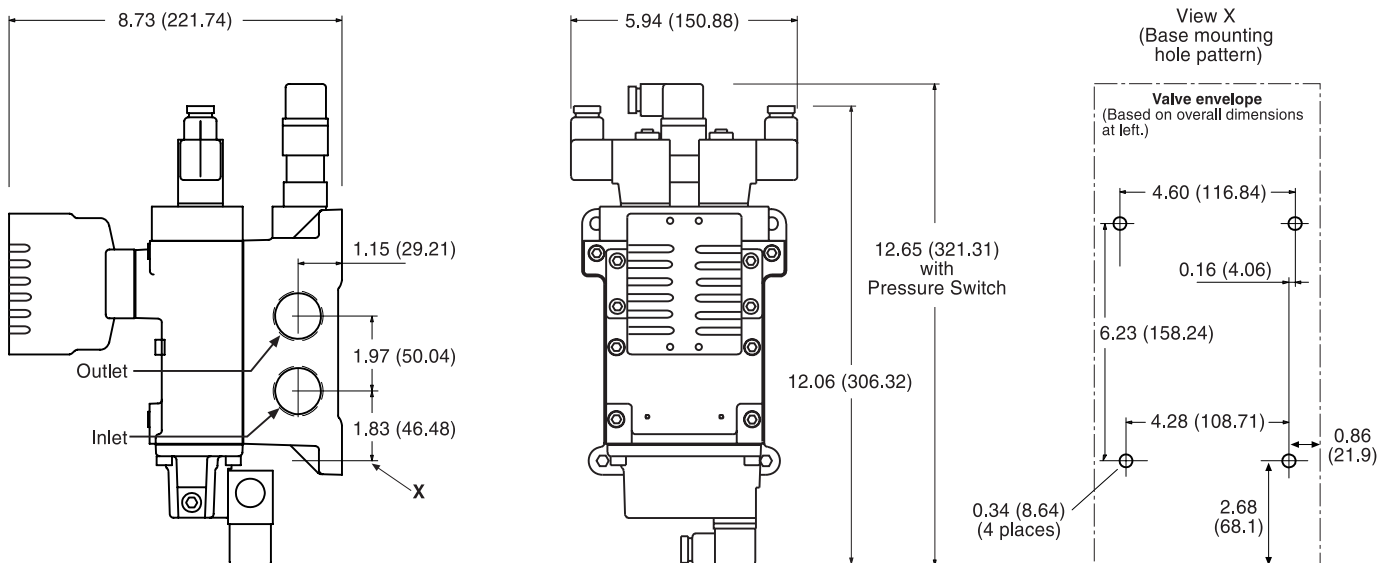



Size 12

U.S. PATENT Nos. 6840258 and 6840259 – other worldwide patents pending.

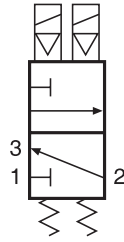

**Simplified Schematic**  
(See page 14 for complete schematic.)

ROSS **DM<sup>2</sup>**™ double valves have been approved by the following testing and certifying authority: BG-PRÜFZERT, Fachausschuss "Maschinenbau, Hebezeuge, Hütten- und Walzwerksanlagen", Germany  
**Certificate Numbers: 06 008 / 06 021**

**IMPORTANT NOTE:** Please read carefully and thoroughly all of the CAUTIONS on page 16.

- **Total Dynamic Monitoring With Complete Memory:** Memory, monitoring, and air flow control functions are simply integrated into two identical valve elements. Valves lock out due to asynchronous movement of valve elements during actuation or de-actuation, resulting in a residual outlet pressure of less than 1% of supply. Overt action is required for reset – cannot be reset by removing and re-applying supply pressure. Reset can only be accomplished by remote air signal or by optional integrated electrical (solenoid) reset.
- **Basic 3/2 Normally Closed Valve Function:** Dirt tolerant, wear compensating poppet design for quick response and high flow capacity. Teflon® back-up rings on pistons to enhance valve endurance – operates with or without inline lubrication.
- **Status Indicator (Optional):** Includes a pressure switch with both N.O. & N.C. contacts to provide status feedback to the press control system indicating whether the valve is in the lock-out or ready-to-run condition. The Status Indicator can be ordered installed or purchased separately and added to any **DM<sup>2</sup>**™ base.
- **Silencers:** All models include high flow, clog resistant silencers.
- **Mounting:** Base mounted – with BSPP or NPT pipe threads. Inlet and outlet ports on both sides provide for flexible piping (plugs for unused ports included). Captive valve-to-base mounting screws.
- **Intermediate Pilots:** Increase pilot air flow for fast valve response, and make it possible to use the same size solenoids as valve sizes 4 & 8, thereby reducing electrical power requirements for these larger valves.

## TECHNICAL SPECIFICATIONS

**Pilot solenoid:** According to VDE 0580. Rated for continuous duty.

**Standard voltages:** 24 VDC, 110 VAC (50/60 Hz), 220\*\* VAC (50/60 Hz). For other voltages consult ROSS. Specify voltage and frequency on order.

**Power consumption for primary and reset solenoids (each solenoid):** 5.8 W on DC; 15.8 VA inrush and 12.8 VA holding on AC.

**Enclosure rating:** IP65, IEC 60529.

**Electrical connection:** DIN 43650, Form A. Order connectors separately. See page 12.

**Ambient temperature:** 15 to 122° F (-10 to 50°C).

**Media temperature:** 40 to 175° F (4 to 80°C).

**Flow Media:** Compressed air, filtered (5µm recommended), lubricated or unlubricated (mineral oils according to DIN 51519/ISO-VG, viscosity classes 32-46).

**Inlet Pressure:** 30 to 120 psig (2 to 8 bar).

**Monitoring:** dynamically, cyclically, internally during each actuating and de-actuating movement. Monitoring function has memory and requires an overt act to reset unit after lock-out.

**Valve weight:** remote reset - 14.6 lbs (6.6 kg). Add 0.3 lbs (0.14 kg) for solenoid reset.

**Mounting orientation:** preferably horizontally (valve on top of base) or vertically (with pilot solenoids on top).

**HOW TO ORDER**

(Choose your options (in red) to configure your valve model number. See pages 5, 7, & 11 for other basic sizes.)

<b>PRODUCT</b>	DM2D	<b>D</b>	<b>A</b>	<b>6</b>	<b>6</b>	<b>A</b>	<b>1</b>	<b>1</b>	<b>STATUS INDICATOR</b>
<b>THREAD</b>									<b>1</b> .....YES
BSPP.....		<b>D</b>							<b>X</b> .....NO
NPT.....		<b>N</b>							
N/A (no base).....		<b>X</b>							
<b>REVISION LEVEL</b>									<b>RESET TYPE</b>
									<b>1</b> .....REMOTE
									<b>2</b> .....SOLENOID
<b>BASIC SIZE</b>									<b>VOLTAGE</b>
12.....					<b>6</b>				<b>A</b> .....24 VDC
									<b>B</b> .....110 VAC
									<b>C**</b> .....220 VAC
<b>BASE PORT SIZE</b>									
1inlet – 1outlet.....					<b>6</b>				
1inlet – 1-1/2 outlet.....					<b>7</b>				
Valve only (less base).....					<b>X</b>				

\*\* 220 VAC not available in the U.S. (OSHA regulations limit press control voltage to no more than 120 VAC.)

**BASE MODEL NUMBERS and BASE SPECIFIC INFORMATION**

Model Number*	Inlet Port	Outlet Port	Status Indicator	Weight lbs (kg)
1705C91	1	1	No	6.2 (2.8)
1706C91	1	1	Yes	6.8 (3.1)
1707C91	1	1-1/2	No	6.2 (2.8)
1708C91	1	1-1/2	Yes	6.8 (3.1)

\*NPT port threads. For BSPP threads add a "D" prefix to the model number. For example, D1705C91.

**DIMENSIONS – inches (mm)**

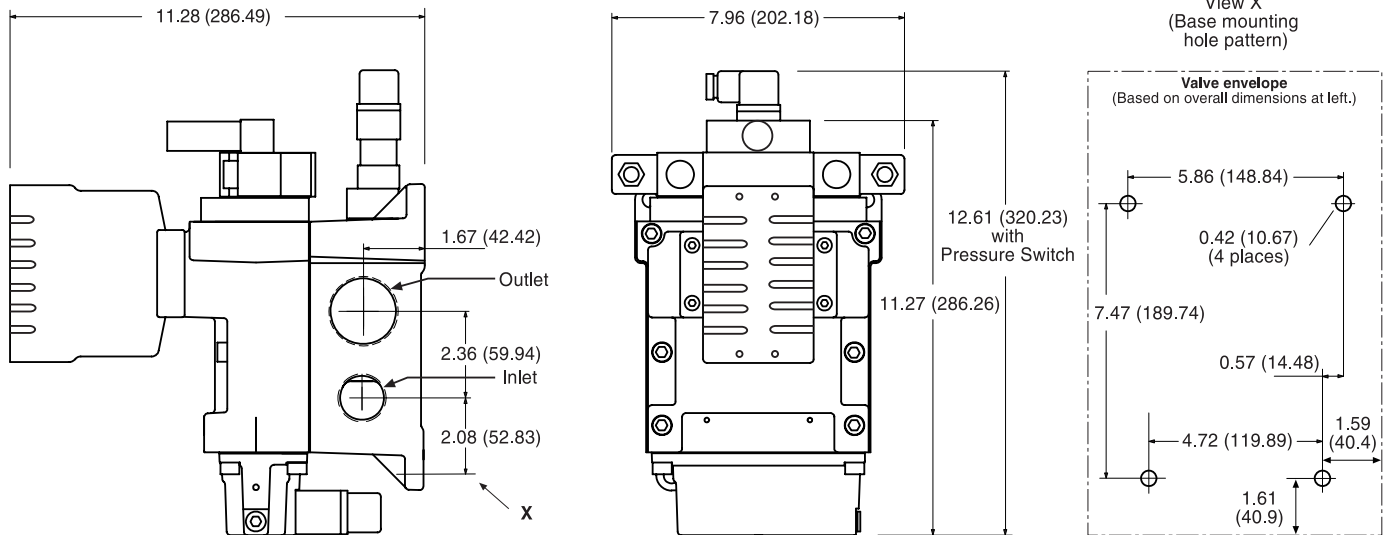

U.S. PATENT Nos. 6840258 and 6840259 – other worldwide patents pending.



Size 30

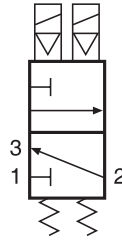

**Simplified Schematic**

(See page 14 for complete schematic.)

ROSS **DM<sup>2</sup>**™ double valves have been approved by the following testing and certifying authority: BG-PRÜFZERT, Fachausschuss "Maschinenbau, Hebezeuge, Hütten- und Walzwerksanlagen", Germany  
**Certificate Numbers: 06 008 / 06 021**

**IMPORTANT NOTE:** Please read carefully and thoroughly all of the CAUTIONS on page 16.

- **Total Dynamic Monitoring With Complete Memory:** Memory, monitoring, and air flow control functions are simply integrated into two identical valve elements. Valves lock out due to asynchronous movement of valve elements during actuation or de-actuation, resulting in a residual outlet pressure of less than 1% of supply. Overt action is required for reset – cannot be reset by removing and re-applying supply pressure. Reset can only be accomplished by remote air signal or by optional integrated electrical (solenoid) reset.
- **Basic 3/2 Normally Closed Valve Function:** Dirt tolerant, wear compensating poppet design for quick response and high flow capacity. Teflon® back-up rings on pistons to enhance valve endurance – operates with or without inline lubrication.
- **Status Indicator (Optional):** Includes a pressure switch with both N.O. & N.C. contacts to provide status feedback to the press control system indicating whether the valve is in the lock-out or ready-to-run condition. The Status Indicator can be ordered installed or purchased separately and added to any **DM<sup>2</sup>**™ base.
- **Silencers:** All models include high flow, clog resistant silencers.
- **Mounting:** Base mounted – with BSPP or NPT pipe threads. Inlet and outlet ports on both sides provide for flexible piping (plugs for unused ports included). Captive valve-to-base mounting screws.
- **Intermediate Pilots:** Increase pilot air flow for fast valve response, and make it possible to use the same size solenoids as valve sizes 4 & 8, thereby reducing electrical power requirements for these larger valves.

## TECHNICAL SPECIFICATIONS

**Pilot solenoid:** According to VDE 0580. Rated for continuous duty.

**Standard voltages:** 24 VDC, 110 VAC (50/60 Hz), 220\*\* VAC (50/60 Hz). For other voltages consult ROSS. Specify voltage and frequency on order.

**Power consumption for primary and reset solenoids (each solenoid):** 5.8 W on DC; 15.8 VA inrush and 12.8 VA holding on AC.

**Enclosure rating:** IP65, IEC 60529.

**Electrical connection:** DIN 43650, Form A. Order connectors separately. See page 12.

**Ambient temperature:** 15 to 122° F (-10 to 50°C).

**Media temperature:** 40 to 175° F (4 to 80°C).

**Flow Media:** Compressed air, filtered (5µm recommended), lubricated or unlubricated (mineral oils according to DIN 51519/ISO-VG, viscosity classes 32-46).

**Inlet Pressure:** 30 to 120 psig (2 to 8 bar).

**Monitoring:** dynamically, cyclically, internally during each actuating and de-actuating movement. Monitoring function has memory and requires an overt act to reset unit after lock-out.

**Valve weight:** remote reset - 31.7 lbs (14.4 kg). Add 0.3 lbs (0.14 kg) for solenoid reset.

**Mounting orientation:** preferably horizontally (valve on top of base) or vertically (with pilot solenoids on top).

**HOW TO ORDER**

(Choose your options (in red) to configure your valve model number. See pages 5, 7, & 9 for other basic sizes.)

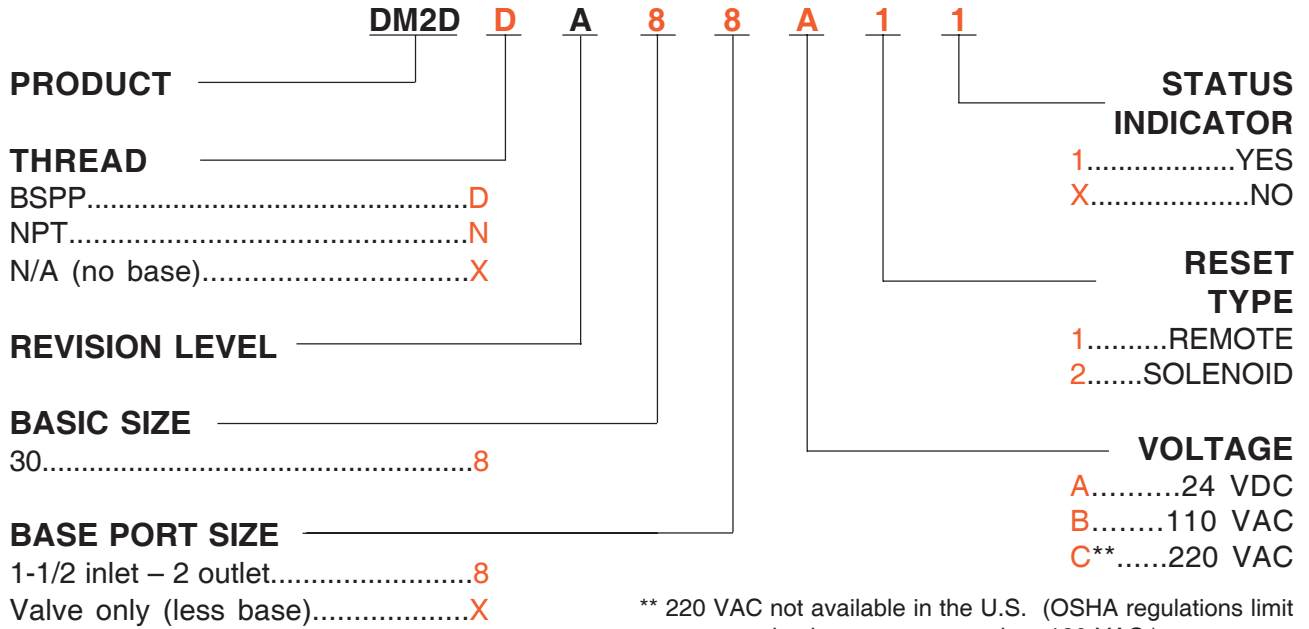

\*\* 220 VAC not available in the U.S. (OSHA regulations limit press control voltage to no more than 120 VAC.)

**BASE MODEL NUMBERS and BASE SPECIFIC INFORMATION**

Model Number*	Inlet Port	Outlet Port	Status Indicator	Weight lbs (kg)
1709C91	1-1/2	2	No	12.0 (5.4)
1710C91	1-1/2	2	Yes	12.6 (5.7)

\*NPT port threads. For BSPB threads add a "D" prefix to the model number. For example, D1709C91.

**DIMENSIONS – inches (mm)**

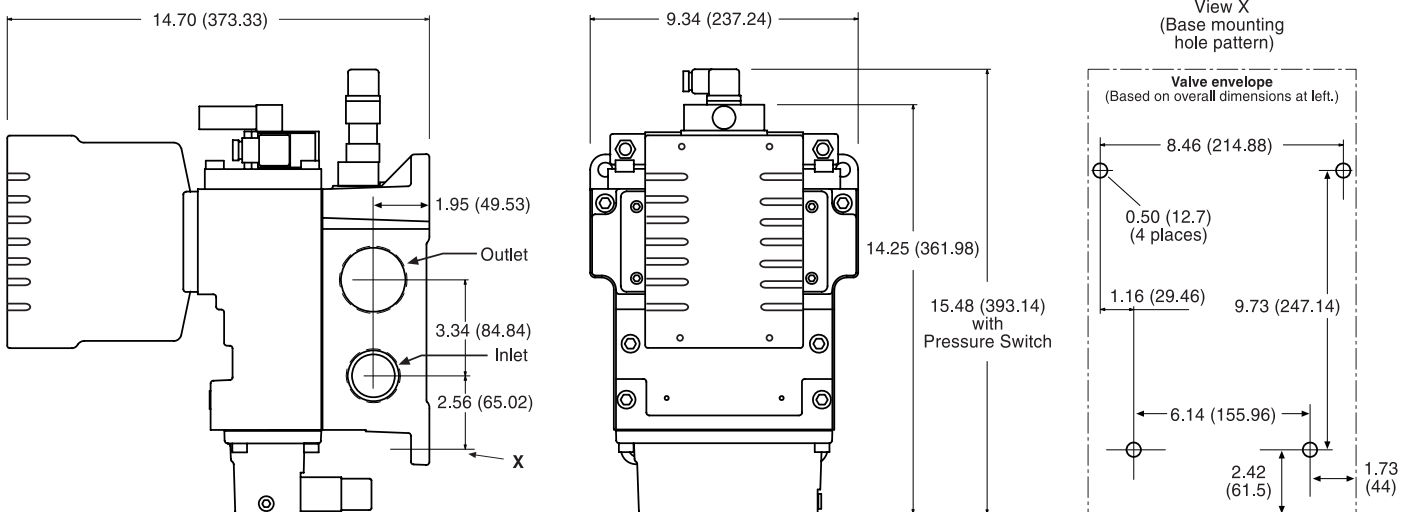

## ACCESSORIES



### STATUS INDICATOR

The Status Indicator pressure switch actuates when the valve is in a ready-to-run condition and de-actuates when the valve is in a lock-out condition or when the inlet air pressure has been removed. Although, the valves can be purchased with this option already installed, the Status Indicator can be purchased separately by ordering part number: **670B94**

### ELECTRICAL CONNECTORS

Electrical connectors are required to connect the valve solenoids to the drop cords supplying electrical power.



Each connector can be positioned so that the cord exits upward or to the side. Cords of 6-mm to 10-mm diameter can be used. Connectors with a light in a translucent housing are also available to serve as indicator lights. Order connectors by the part numbers given in the chart below.

**WIRED CONNECTORS** have a 2-meter (6-1/2 ft.) cord with three 18-gauge conductors. Cord exits upward, and is available in either 6-mm or 10-mm diameter.

**CONNECTORS for THREADED CONDUIT** accept 1/2-inch electrical conduit fittings.

**CAUTION:** Do not use electrical connectors with surge suppressors, as this may increase valve response time when de-actuating the solenoids.

### RESET VALVES for MODELS with REMOTE RESET

On valve models with solenoid reset, a solenoid on the valve is actuated to perform the reset function. Models for remote reset, however, require a small reset valve and the installation of a 1/8 line from the reset valve to the reset port on the double valve. ROSS offers 3/2 normally closed valves with either manual or electric control that are suitable for this purpose. The valves, pictured below, are suggested (EN 692 to be observed).

#### Model Numbers of Reset Valves

Description	Valve Model Numbers
Pushbutton: Green	1223A1005
Direct Solenoid Control for line mounting	1613B1020*
Direct Solenoid Control for base mounting	W1413A1409* (Base: 516B91)

For BSPP threads, add a D prefix to the model number. For example, 1223A1005 becomes D1223A1005. In the case of the W1413A1409, the prefix should be added to the base model instead of the valve.

#### Part Numbers of Electrical Connectors

Connector Type	Without Light	With Light*
For use with dropcord (Cord not included)	937K87	936K87*
Wired with 6-mm cord	721K77	720K77*
Wired with 10-mm cord	371K77	383K77*
For use with threaded conduit	723K77	724K77*



**Pushbutton Models**  
Green button: 1223A1005

**Direct Solenoid Model  
for Line Mounting**  
1613B1020\*



**Direct Solenoid Model  
for Base Mounting**  
Valve: W1413A1409\*  
Sub-Base: 516B91

\* Specify solenoid voltage and Hz when ordering.

# VALVE RESPONSE CHARTS

The charts below represent the fill and exhaust times for each of the various sizes of **DM<sup>2</sup>**™ valves. The “fill” times were measured while raising (filling) the pressure in a volume from 0 to 2, 4, & 5.4 bar (0 to 30, 60, & 80 psi) with a 6 bar (90 psi) inlet pressure. Conversely, the “exhaust” times were measured while lowering the pressure (exhausting) in a volume from 6 bar (90 psi) down to 4, 2, & 0.6 bar (90 to 60, 30, & 9 psi). **Exhausting tests performed with silencer installed.**

## Filling

## Exhausting

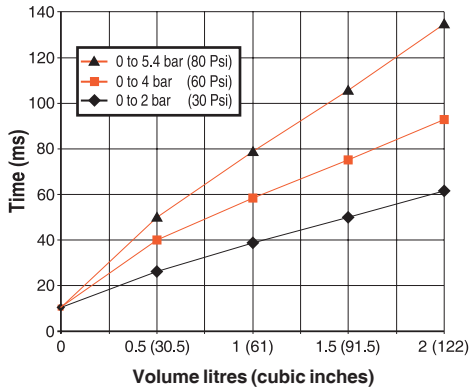

Size 4

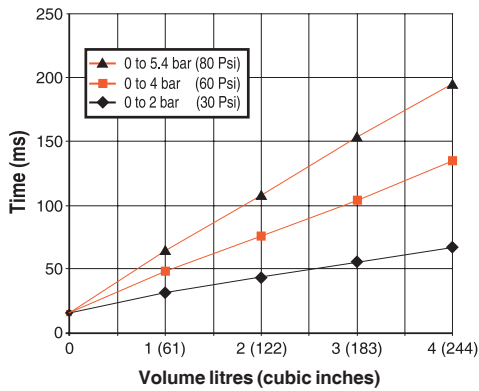
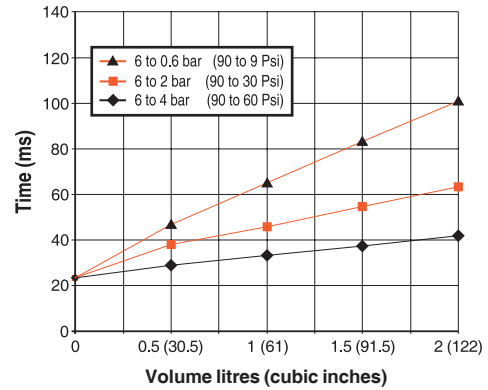

Size 8

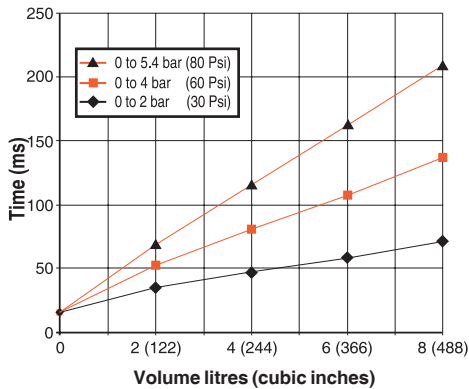
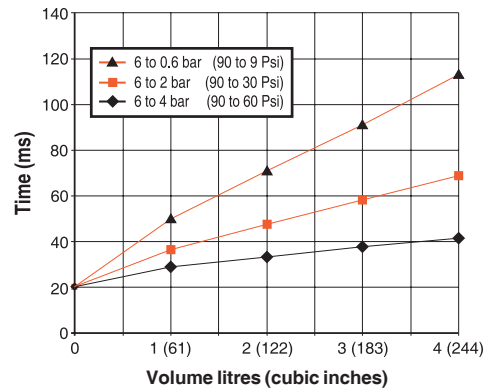

Size 12

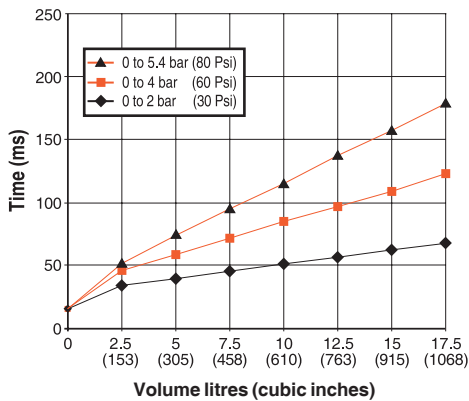
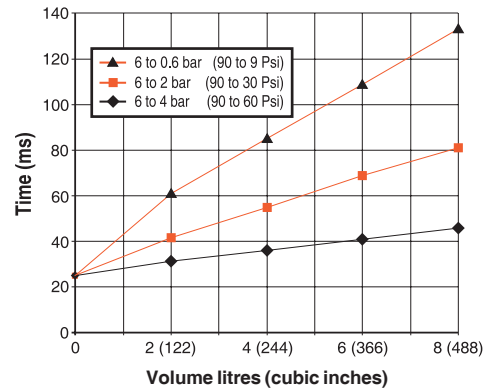

Size 30

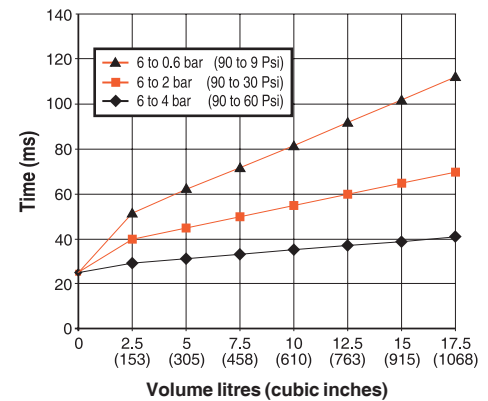

# VALVE SCHEMATIC

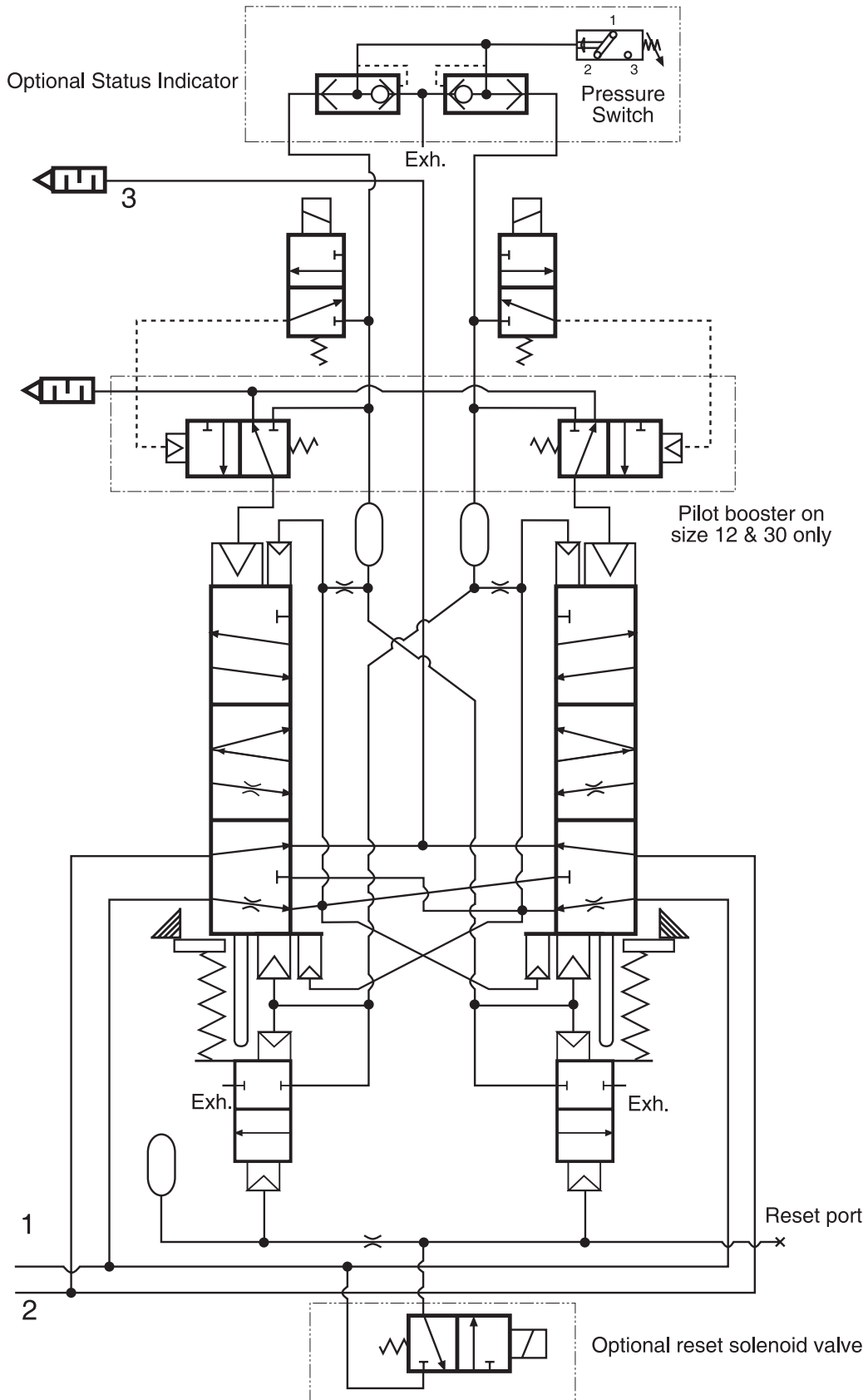

# APPLICATION & SAFETY CATEGORY

## 1. General

This new valve design is of considerable importance to users of double valves on mechanical power press applications (EN 692) and other critical applications as this product is designed to meet the latest standards requiring “control reliable” (EN 954), “Category-3 & -4”, or “dynamic monitoring” capability.

The monitoring and memory capabilities of this valve are both built into the two piston-poppet stem assemblies. During normal operation, the assemblies move between two extreme positions, the 3rd, or intermediate, position occurs during valve lock-out. The valve will lock out whenever there is sufficient asynchronous motion between the two piston-poppet stem assemblies. No additional external or internal devices are needed to provide monitoring and memory. When the inlet air supply is removed and re-applied, the valve “remembers” whether it was in the ready-to-run or locked-out position prior to the removal of the air supply.

Resetting the valve after it has locked out requires a momentary application of a reset signal. Should the reset signal be inadvertently left on (permanent signal), the valve will nevertheless lock-out when there has been asynchronous motion of the two valve elements.

## 2. Description

The three way valve with **DM<sup>2</sup>**™ capability consists of two main valve systems and two pilot valve systems. The air flow paths within the main valve systems are a proven combination of both **SERIES** and **PARALLEL** paths, and described by the trade name **SERPAR**®.

Both pilot valves and both main valve elements are interconnected with each other pneumatically. The main valve elements control the air via Crossflow™ air passages from inlet (port 1) to outlet (port 2). Air flows first through a control element on one side of

the valve to a control element on the second side of the valve, hence a series flow path. A parallel flow path starts on the second side of the valve and flows to the first side of the valve. A total of four elements control air flow from inlet to outlet. Air flow from outlet (port 2) to exhaust port (port 3) occurs in parallel via the exhaust poppets of both main valve elements.

In normal operation, pilot air supply is maintained as long as the two main elements operate in a synchronous manner. Whenever there is asynchronous motion, one of the pilot air supplies will be exhausted.

Sufficient pilot pressure is necessary to move the main valve elements to their fully actuated or de-actuated positions. Lack of sufficient pilot pressure will prevent a valve element from fully shifting, resulting in the element stopping in the intermediate, locked-out position.

## 3. Application

Uncontrolled movements of cylinders or rotary drives can cause harm to personnel and machinery. In order to prevent injuries and damage, pneumatic controls have to meet strict safety requirements.

ROSS developed the **DM<sup>2</sup>**™ valves for controlling pneumatic clutch and brake mechanisms on mechanical power presses. However, the features and functions built into the valve make it an ideal product to meet the specifications and standards associated with other critical applications. Because of its redundant design and the fact that the air is directed in a Crossflow™ SERPAR® pattern, the **DM<sup>2</sup>**™ valve provides a very high level of safety.

## INSTALLATION EXAMPLE

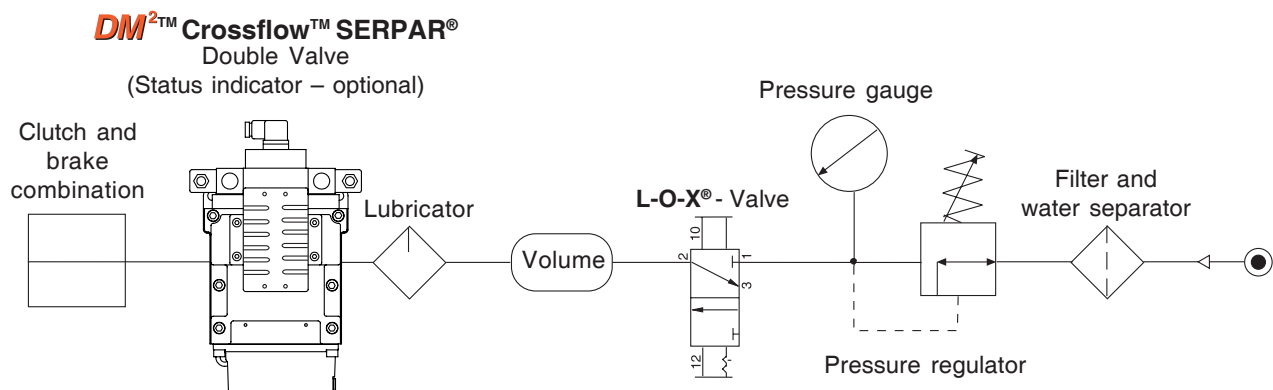

# CAUTIONS

## PRE-INSTALLATION or SERVICE

1. Before servicing a valve or other pneumatic component, be sure that all sources of energy are turned off, the entire pneumatic system is shut off and exhausted, and all power sources are locked out (ref: OSHA 1910.147, EN 1037).
2. All ROSS products, including service kits and parts, should be installed and/or serviced only by persons having training and experience with pneumatic equipment. Because any installation can be tampered with or need servicing after installation, persons responsible for the safety of others or the care of equipment must check every installation on a regular basis and perform all necessary maintenance.
3. All applicable instructions should be read and complied with before using any fluid power system in order to prevent harm to persons or equipment. In addition, overhauled or serviced valves must be functionally tested prior to installation and use.
4. Each ROSS product should be used within its specification limits. In addition, use only ROSS parts to repair ROSS products. Failure to follow these directions can adversely affect the performance of the product or result in the potential for human injury.

## FILTRATION and LUBRICATION

5. Dirt, scale, moisture, etc. are present in virtually every air system. Although some valves are more tolerant of these contaminants than others, best performance will be realized if a filter is installed to clean the air supply, thus preventing contaminants from interfering with the proper performance of the equipment. ROSS recommends a filter with a 5-micron rating for normal applications.
6. All standard ROSS filters and lubricators with polycarbonate plastic bowls are designed for compressed air applications only. Do *not* fail to use the metal bowl guard, where provided, to minimize danger from high pressure fragmentation in the event of bowl failure. Do not expose these products to certain fluids, such as alcohol or liquefied petroleum gas, as they can cause bowls to rupture, creating a combustible condition, hazardous leakage, and the potential for human injury. Immediately replace a crazed, cracked, or deteriorated bowl. When bowl gets dirty, replace it or wipe it with a clean dry cloth.

7. Only use lubricants which are compatible with materials used in the valves and other components in the system. Normally, compatible lubricants are petroleum base oils with oxidation inhibitors, an aniline point between 180°F (82°C) and 220°F (104°C), and an ISO 32, or lighter, viscosity. Avoid oils with phosphate type additives which can harm polyurethane components, potentially leading to valve failure and/or human injury.

## AVOID INTAKE/EXHAUST RESTRICTION

8. Do not restrict the air flow in the supply line. To do so could reduce the pressure of the supply air below the minimum requirements for the valve and thereby cause erratic action.
9. Do not restrict a poppet valve's exhaust port as this can adversely affect its operation. Exhaust silencers must be resistant to clogging and have flow capacities at least as great as the exhaust capacities of the valves. Contamination of the silencer can result in reduced flow and increased back pressure.

*ROSS expressly disclaims all warranties and responsibility for any unsatisfactory performance or injuries caused by the use of the wrong type, wrong size, or inadequately maintained silencer installed with a ROSS product.*

## POWER PRESSES

10. Mechanical power presses (EN 692) and other potentially hazardous machinery using a pneumatically controlled clutch and brake mechanism must use a press control double valve with a monitoring device. A double valve without a self-contained monitoring device should be used only in conjunction with a control system which assures monitoring of the valve. All double valve installations involving hazardous applications should incorporate a monitoring system which inhibits further operation of the valve and machine in the event of a failure within the valve mechanism.

## ENERGY ISOLATION/EMERGENCY STOP

11. Per specifications and regulations, ROSS **L-O-X®** and **L-O-X®/EEZ-ON®** products are defined as energy isolation devices, NOT AS EMERGENCY STOP DEVICES.

## MAIN VALVE INTERNALS

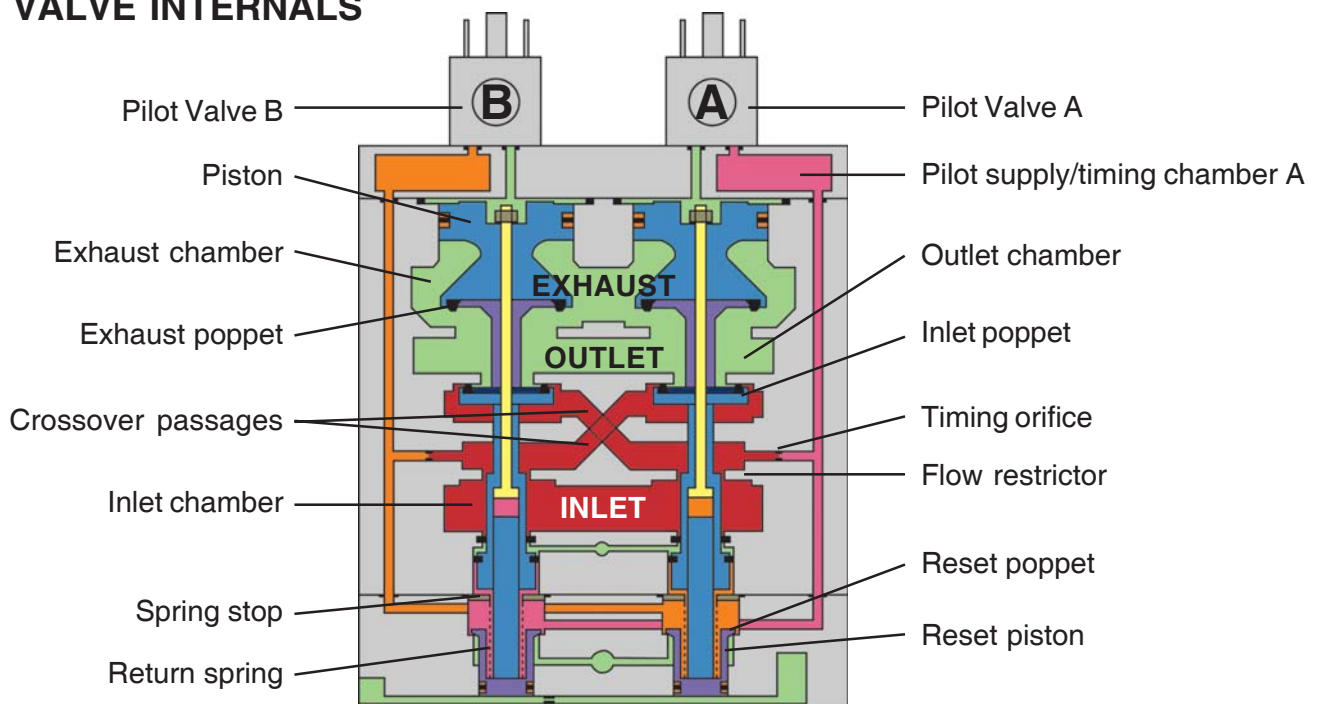

# OPERATING INSTRUCTIONS

## Start-up

Before start-up, the installation must be checked thoroughly by persons trained and experienced in the operation of pneumatic equipment. Make sure that specifications given on the valve label (e.g. "max. operating pressure" and "electrical characteristics") will be in accordance with the operating specifications of the press. When operating pressure is initially applied, it may be necessary to actuate the reset valve momentarily to move the main valve into the ready-to-run condition. Make sure that the inlet supply and the exhaust path are not restricted. Operating pressure must comply with the minimum and maximum limits.

## Functional test

Test	Result
1. Solenoid "A" actuated	Valve moves into lock-out mode, slight leakage at exhaust port 3
2. Solenoid "B" actuated	Valve moves into lock-out mode, slight leakage at exhaust port 3
3. Solenoids "A" and "B" actuated with $\Delta t < 0.1$ s	Valve operates properly
4. Solenoids "A" and "B" actuated with $\Delta t > 0.1$ s	Valve moves into lock-out mode, slight leakage at exhaust port 3
5. After lock-out, permanent signal on reset valve - solenoids "A" and "B" or only "A" / only "B" actuated	Valve cannot be moved into ready-to-run mode

## Pressure test

After a valve lock-out, the double valve must be moved into the ready-to-run position by using the reset valve. In general, if the valve is in the lock-out mode and one or both of the solenoids are energized, the valve should not reset with application or application and removal of the reset signal. If the valve is in the ready-to-run mode with the reset valve actuated, the valve will function normally with application and removal of pilot solenoid signal. However, if the valve elements cycle asynchronously, the valve will go to the lock-out mode. Provided that both solenoids are de-energized, removal of reset signal will return the valve to the ready-to-run mode.

An additional test to perform:

- With the valve in the ready-to-run mode, exhaust and re-pressurize the inlet port. The valve should remain in the ready-to-run mode.
- With the valve in the lock-out mode, exhaust and re-pressurize the inlet port. The valve should remain in the lock-out mode.

## Lock-outs

Any asynchronous movement between both piston elements for a time period  $> 0.1$  s will result in a lock-out of the valve. This can be due to various causes. For instance:

- worn piston seals
- delayed response of the main valve elements due to dirt or varnished lubricant.
- electrical signals to solenoid incomplete or unable to maintain proper voltage.

- independent electrical signals to solenoids are not received concurrently.
- delayed response of solenoid pilots or booster pilots due to damaged components, dirt, or varnished lubricant.
- collection of excessive water or lubrication.

## Maintenance, Testing

Maintenance and testing procedures must follow the rules and regulations set by the respective national work-safety institutions. These procedures should only be performed by persons trained and experienced in the use of pneumatic equipment. Regulations generally require that maintenance and test procedures be performed at least once a year.

## Repair

ROSS would be happy to service this specialized double valve for you at its factory repair center. Call your local ROSS office or distributor (in the U.S. 1-800-GET-ROSS or +706-356-3708 outside the U.S.) for information. If you service the valve yourself, be sure to turn off electrical power to the valve, shut off the air supply, exhaust the air in the system, and lock-out all power sources before beginning any disassembly operation. Customers maintaining their own valves should make sure that only original spare parts (as specified in the ROSS parts lists) are used. Pneumatic equipment should be repaired only by persons trained and experienced in the repairing of such equipment, guided by these operating instructions. Information about valve repair and/or the exchange of a valve must be written down in the machine operation documentation.

# REPAIR KITS

## Sizes 4 & 8

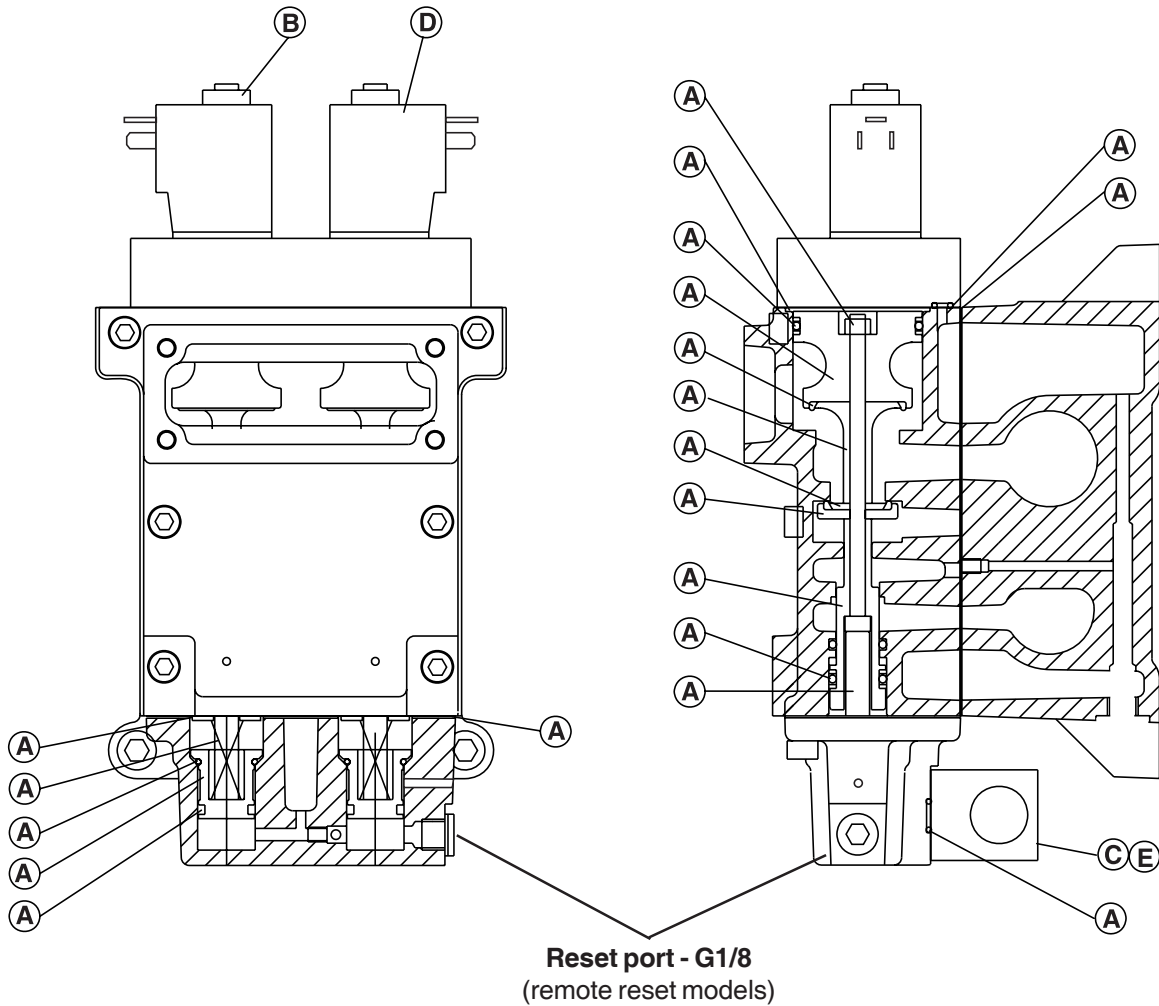

Item	Description	Size 4	Size 8
A	Valve body service kit	2102K77	2103K77
B*	Complete primary solenoid pilot	1403H79	1404H79
C*	Complete reset solenoid pilot	851C79	851C79
D*	Solenoid coil – pilots	306K33	360K33
E*	Solenoid coil – reset	306K33	306K33

\* Specify solenoid voltage and Hz when ordering.

### Kits for optional items (not shown in the drawing above):

Status indicator assembly service kit – **2151H77**

Replacement pressure switch – **1018A30**

# REPAIR KITS

## Sizes 12 & 30

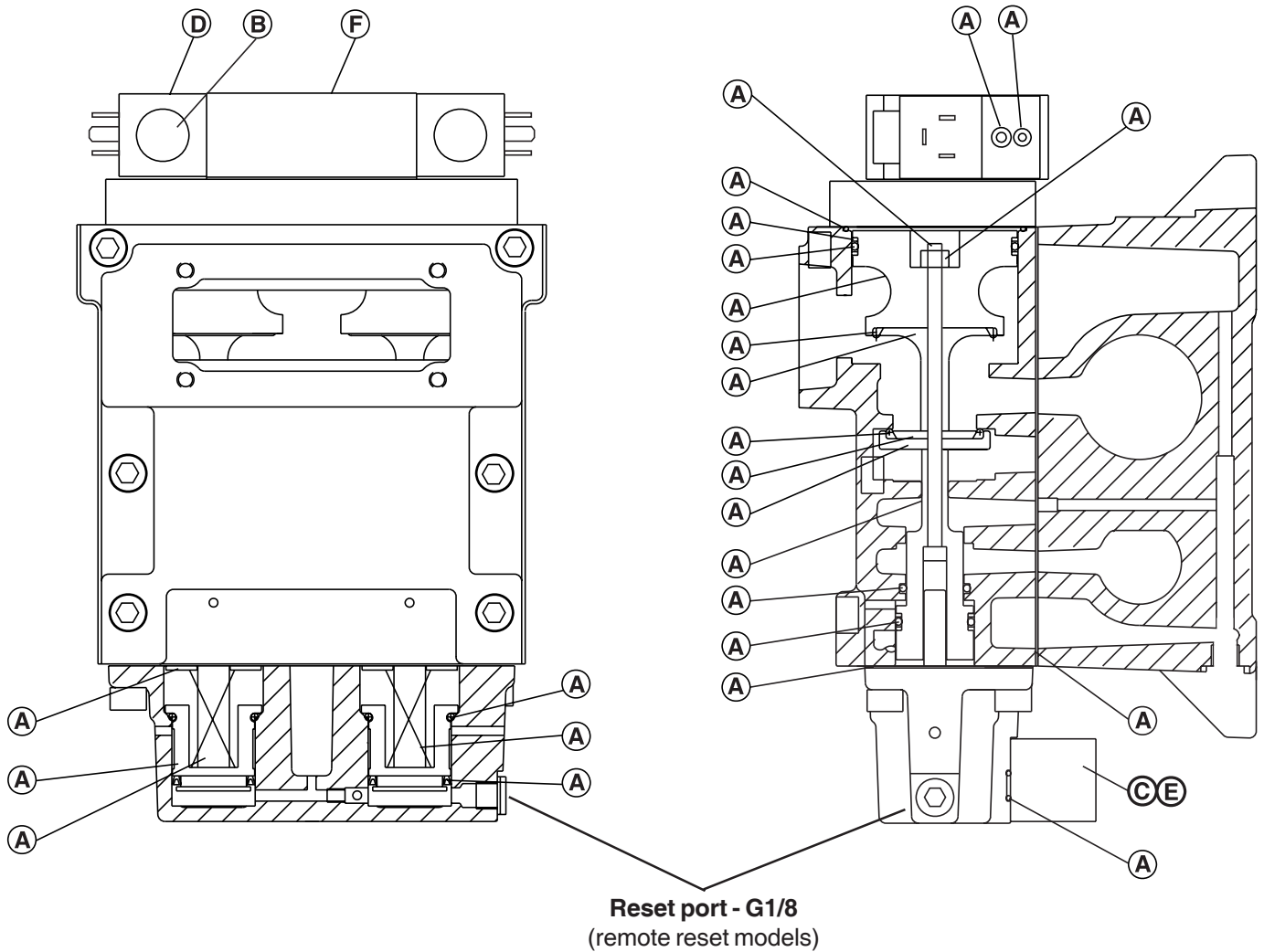

Item	Description	Size 12	Size 30
A	Valve body service kit	2104K77	2105K77
B*	Complete primary solenoid pilot	1391K79	1391K79
C*	Complete reset solenoid pilot	851C79	851C79
D*	Solenoid coil – pilots	306K33	306K33
E*	Solenoid coil – reset	306K33	306K33
F	Pilot booster service kit	2106K77	2106K77

\* Specify solenoid voltage and Hz when ordering.

### Kits for optional items (not shown in the drawing above):

Status indicator assembly service kit – **2151H77**

Replacement pressure switch – **1018A30**



**GLOBAL Reach with a LOCAL Touch<sup>sm</sup>**

**ROSS CONTROLS®**

Troy, MI., U.S.A.

Telephone: + 1-248-764-1800

Fax: + 1-248-764-1850

In the United States:

Customer Service: 1-800-GET ROSS  
(438-7677)

Technical Service: 1-888-TEK-ROSS  
(835-7677)

[www.rosscontrols.com](http://www.rosscontrols.com)

**ROSS UK Ltd.**

Birmingham, United Kingdom

Telephone: + 44-121-559-4900

Fax: + 44-121-559-5309

Email: [sales@rossuk.co.uk](mailto:sales@rossuk.co.uk)

**ROSS SOUTH AMERICA Ltda.**

São Paulo, Brazil CEP 09725-020

Telephone: + 55-11-4335-2200

Fax: + 55-11-4335-3888

Email: [vendas@ross-sulamerica.com.br](mailto:vendas@ross-sulamerica.com.br)

**ROSS EUROPA® GmbH**

Langen, Germany

Telephone: + 49-6103-7597-0

Fax: + 49-6103-74694

Email: [info@rosseuropa.com](mailto:info@rosseuropa.com)

[www.rosseuropa.com](http://www.rosseuropa.com)

**ROSS ASIA® K.K.**

Kanagawa, Japan

Telephone: + 81-427-78-7251

Fax: + 81-427-78-7256

[www.rossasia.co.jp](http://www.rossasia.co.jp)

**ROSS CONTROLS (CHINA) Ltd**

Shanghai, China

Telephone: + 86-21-6267-5010

Fax: + 86-21-6267-5008

**ROSS CONTROLS® INDIA Pvt. Ltd.**

Chennai, India

Telephone: + 91-44-2624-9040

Fax: + 91-44-2625-8730

*Your local ROSS distributor is:*

## Warranty

Products manufactured by ROSS are warranted to be free of defects in material and workmanship for a period of one year from the date of purchase. ROSS' obligation under this warranty is limited to repair or replacement of the product or refund of the purchase price paid solely at the discretion of ROSS and provided such product is returned to ROSS freight prepaid and upon examination by ROSS such product is found to be defective. This warranty shall be void in the event that product has been subject to misuse, misapplication, improper maintenance, modification or tampering. THE WARRANTY EXPRESSED ABOVE IS IN LIEU OF AND EXCLUSIVE OF ALL OTHER WARRANTIES AND ROSS EXPRESSLY DISCLAIMS ALL OTHER WARRANTIES EITHER EXPRESSED OR IMPLIED WITH RESPECT TO MERCHANTABILITY OR FITNESS FOR A PARTICULAR PURPOSE. ROSS MAKES NO WARRANTY WITH RESPECT TO ITS PRODUCTS MEETING THE PROVISIONS OF ANY GOVERNMENTAL OCCUPATIONAL SAFETY AND/OR HEALTH LAWS OR REGULATIONS. IN NO EVENT SHALL ROSS BE LIABLE TO PURCHASER, USER, THEIR EMPLOYEES OR OTHERS FOR INCIDENTAL OR CONSEQUENTIAL DAMAGES WHICH MAY RESULT FROM A BREACH OF THE WARRANTY DESCRIBED ABOVE OR THE USE OR MISUSE OF THE PRODUCTS. NO STATEMENT OF ANY REPRESENTATIVE OR EMPLOYEE OF ROSS SHALL EXTEND THE LIABILITY OF ROSS AS SET FORTH HEREIN.